

## SAMPLE VENT AND DRAIN VALVE

- ◆ **COMPACT AND ROBUST STAINLESS STEEL CONSTRUCTION**
- ◆ **AUTOMATICALLY RELEASES LOCKED IN PRESSURE WHEN HOSE UNIT IS CONNECTED**
- ◆ **TWIN BALL VALVE DESIGN FOR SAFER OPERATION**
- ◆ **PRESSURE RELIEF VALVE IN THE BASE FLANGE RELEASES TRAPPED PRESSURE AT SET VALUE**
- ◆ **CONNECTS TO 1.1/2 INCH STANAG 3756 STANDARD INDUSTRIAL COUPLINGS**



### Introduction.

It is a requirement for aviation fuel hydrant pipelines to include dedicated low point drains and high point vents. JIG 2 states that low point drains are flushed at a high velocity once a week to ensure removal of any water or sediment.

High point vents are required to bleed air from the hydrant system, for example after filling a section of the hydrant following engineering work.

### Description.

The Aljac Sample Vent and Drain, model EW00001310, is designed for locating on the riser flange inside the hydrant pit box. It comprises a Stainless Steel 6 inch ANSI B16.5 Class 300lb raised face base flange to which two off manually operated 1.1/2 inch Stainless Steel ball valves are fitted. On top of the ball valves there is a flanged Stainless Steel tank unit which features a pressure relief valve in the poppet. This tank unit provides a leak-proof connection when coupled to the

mating hose unit. It includes a depressurisation feature which automatically releases locked in pressure when the hose unit is connected, so that there is no need for a separate manual pressure relief valve in the tank unit body.

Threaded into the 6 inch base flange there is a safety relief valve which is set to the required pressure, but this can be actuated manually if required.

The unit is shipped assembled and includes 3 off non-metallic 1.1/2 inch flat gaskets between the tank unit, ball valves and base flange.

### Operation.

The pit flushing vehicle hose unit is connected to the tank unit. The lower ball valve is opened and the hydrant system can either be flushed or excessive air can be vented using the upper ball valve.

**Dimensions.**

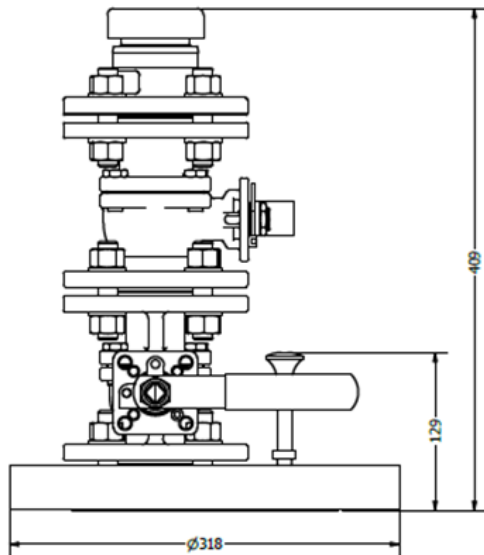
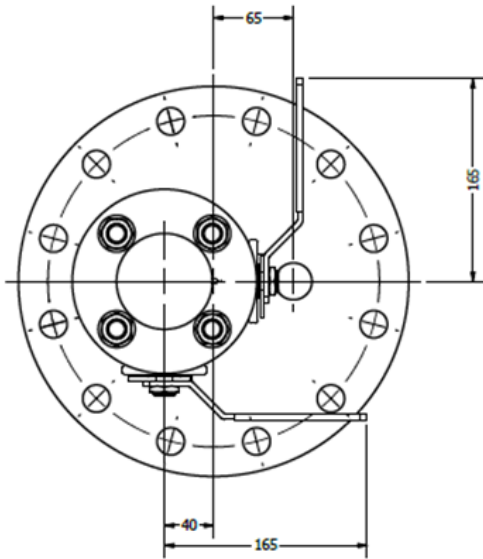

ITEM	QTY	DESCRIPTION
1	1	High Low Point 6in ASME B16.5 Class
2	1	Safety Relief Valve
3	2	1 1/2" Ball Valve
4	1	Tank Unit
5	1	PE Dust Cap
6	3	DN40 Gasket
7	8	M16 Stud Bolt
8	4	M16 Engineering Stud
9	20	M16 Washer
10	20	M16 Hex Nut

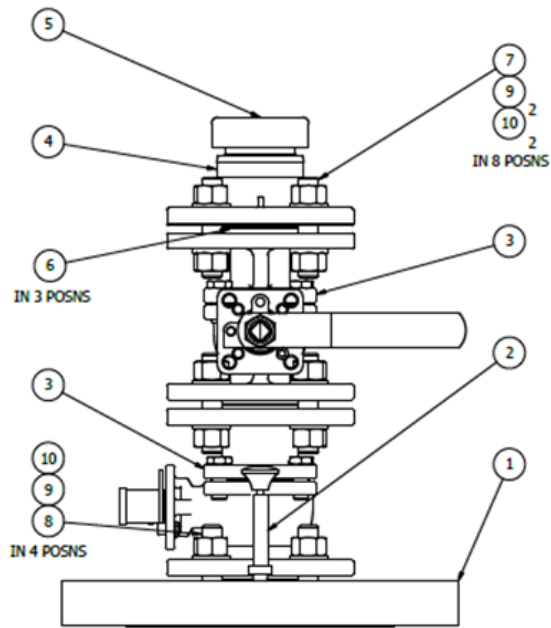

**Specification.**

**Base Flange:** 6 inch ANSI B16.5 Class 300lb raised face, type 304 Stainless Steel.

**Ball Valves:** 1.1/2 inch, Stainless Steel 1.4408 housing and ball, full bore, firesafe to API607, Teflon seals, flanges DN40 PN16.

**Tank Unit:** 1.1/2 inch tank unit to NATO STANAG 3756, Stainless Steel, flanged DN40 PN 10/16. Poppet includes a pressure relief valve to automatically release locked in pressure.

**Pressure Relief Valve:** Stainless Steel 1.4404 construction, suitable for liquid and gas use, venting to atmosphere, 19.5 Bar set pressure, manual operation possible.

**Gaskets:** According to ISO7483, non-metallic flat gaskets, inside bolt circle PN16 M40 1.2.

**Design Temperature:** -20°C to +80°C.

**Design Pressure:** 40 Bar.

**Shipping Specification.**

**Shipping Dimensions (Unpacked):** 318mm x 318mm x 409mm high.

**Nett Weight:** 38.5 Kg.

**How To Order.**

Simply quote the following part number:-

**EW00001310:** Aljac Sample Vent and Drain Valve.

Please contact our Sales Department if you require spare parts or a mating Hose Unit.

**NOTE.** When used for low point sampling an extension pipe must be welded into the Base Flange and must reach into the sump. This is not included but the Base Flange is bored to 50mm diameter into which the 1.1/2 inch N.B. extension pipe can be socket welded.