

# ISO45 AVIATION GROUND UNIT

- ◆ **COMPACT AND LIGHTWEIGHT**
- ◆ **ROBUST ALUMINIUM CONSTRUCTION**
- ◆ **HARD WEARING ALUMINIUM BRONZE ISO45 ADAPTOR**
- ◆ **3/8 INCH BSPP TAPPING IN BODY (FLANGED VERSION ONLY)**
- ◆ **SUITABLE FOR DEPOT OR VEHICLE USE**
- ◆ **TW1 FLANGE OR 2.1/2 INCH BSPP FEMALE THREADED VERSIONS**



## Introduction.

The Aljac Aviation Ground Unit has been manufactured with quality and value in mind for use in aviation refuelling systems in conjunction with 2.1/2 inch ISO45 aviation hose units. The light weight Aluminium body has a black anodised finish for long life and scratch resistance, and the ISO45 Adaptor is produced from hard wearing Aluminium Bronze.

## Description.

The Aljac Aviation Ground Unit has a non-selective Aluminium Bronze ISO45 Adaptor, anodised Aluminium body, Viton seals, and is available with either a TW1 flat face flange or a 2.1/2 inch BSPP female thread.

The TW1 flanged version is supplied with a 3/8 inch BSPP female tapping in the body. This can be fitted with the GTP-235-3/8AH Jet Test QD to allow a contamination test to be performed using a Minimonitor Kit or Millipore Test Kit. (See DSS0144-11 Gammon contamination kits).

**Note:** The 2.1/2 inch BSPP female threaded version is not available with the 3/8 inch BSPP tapping.

The maximum working pressure for both versions is 10.2 Bar and is for use where locked in coupling pressure does not exceed 5.5 Bar.

*The TW1 flanged Ground Unit is equivalent to and interchangeable with the Meggitt FCMY107M5LC and Aljac 40FCMY107M5LJAC.*

*The 2.1/2 inch BSPP threaded Ground Unit is equivalent to and interchangeable with the Meggitt FCMY108M5L.*

Also available is a sealing cap which fits the Ground Unit and should be used to prevent the ingress of dirt or water. It also fits other manufacturer's units which meet the ISO45 standard.

*It is equivalent to and interchangeable with the Meggitt FCMY122M2.*

## How to order.

Simply quote the following part numbers:-

**42FCMY107M5LJAC.** Ground Unit, ISO45 non-selective with TW1 flange and 3/8 inch BSPP tapping.

**42FCMY108M5L.** Tank Unit, ISO45 non-selective with 2.1/2 inch BSPP female thread.

**42FCMY122M2.** Ground unit cap ISO45.

**600202353A.** GTP-235-3/8AH Jet Test QD.

## General Arrangement Drawing.

All dimensions in Millimeters unless otherwise stated.

### 42FCMY107M5LJAC

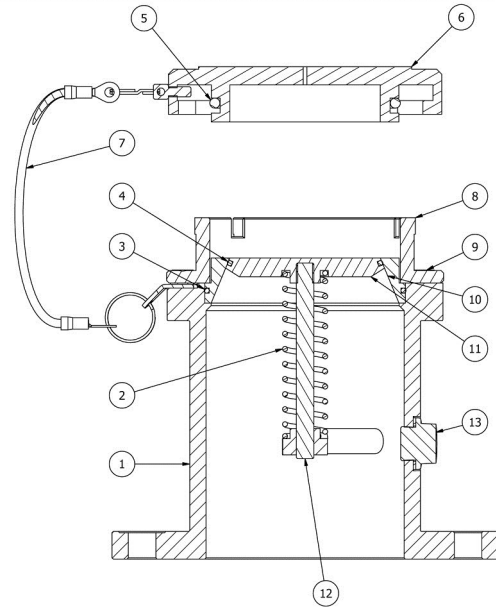
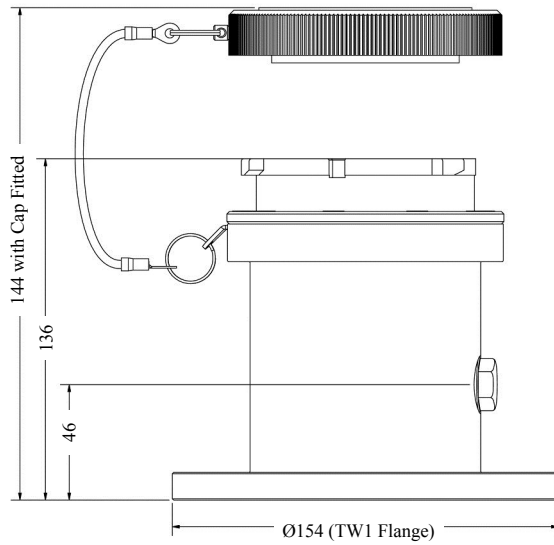

### 42FCMY108M5L

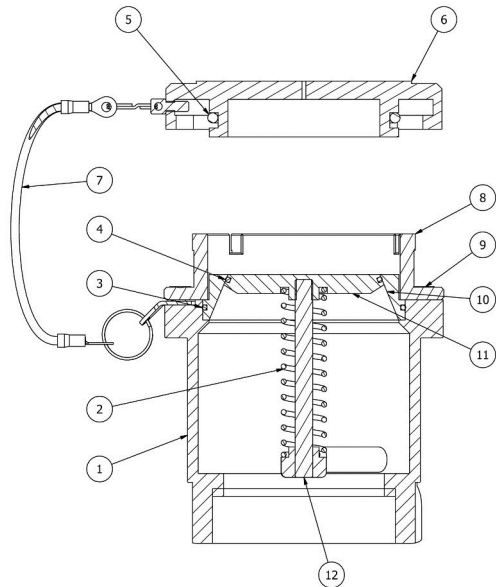
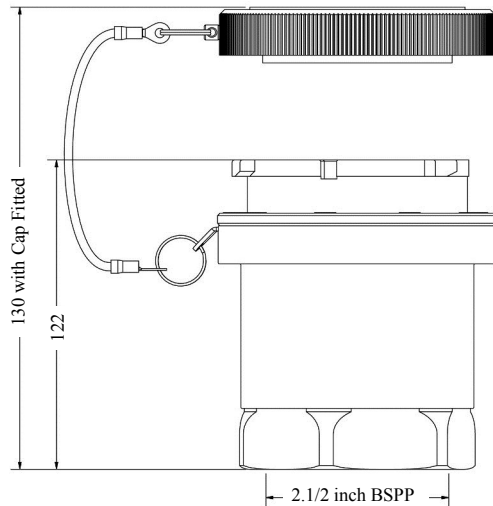

Pos	Item	Qty
1	Body	1
2	Spring	1
3	O-Ring	1
4	O-Ring	1
5	O-Ring	1
6	Cap	1
7	Cable assy	1

Pos	Item	Qty
8	ISO45 adaptor	1
9	Screw DIN 963	9
10	Valve Seat	1
11	Poppet	1
12	Shaft	1
13	Plug 3/8 inch BSPP	1

All internal components are common for both 42FCMY107M5LJAC and 42FCMY108M5L versions.

**Note:** When the Poppet is in the open position the Shaft does not extend past the base of the unit as it may do with other manufacturer's units.

### Applicable Standards.

ISO45.  
TW1.

### Materials.

**Body/cap:** Anodised Aluminium.  
**ISO45 Adaptor:** Aluminium Bronze.  
**Seals:** Viton.

### **Nett weight:**

42FCMY107M5LJAC. 1.66 Kg.  
42FCMY108M5L. 1.16 Kg.  
42FCMY122M2. 0.26 Kg.