

AIRCRAFT REFUELLING NOZZLES

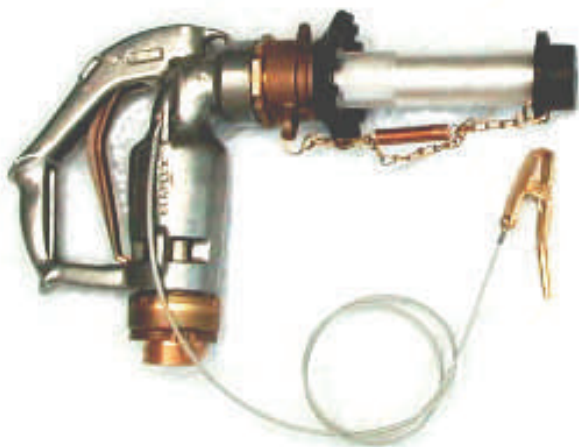

ZVF40

ZVF40. Specification

Type. Aviation refuelling 1.1/2" trigger nozzle for use with Avgas or Jet A1, with integral sight glass and internal check valve.

Operation. Manual deadman lever with notches in the guard for operator assistance (these cannot be used to latch the nozzle open), no high level cut off.

Flow Rate. Up to 400 Litres/Minute.

Maximum Working Pressure. 10 Bar.

Materials Of Construction. Aluminium body and guard, Brass inlet swivel, Stainless Steel and Acetal internals, Nitrile/Vulkollan seals.

Inlet Connection. Swivel type, threaded 1.1/2" BSPP male (BSPP female as an option).

Nett Weight. Approx. 4.0 Kg with spout fitted.

Accessories (to be ordered separately).

Bonding cable and clip, 1.2m or 2.0 metres long.

Quick release spouts, 32 mm and 38 mm bore circular section for Avgas, collar type and oval section type for Jet A1 selectivity. Each spout is fitted with a 100 mesh strainer and an anti splash bump protector.

Dust cap with spring loaded keep chain to suit the spout fitted.



ZVF25

ZVF25. Specification

Type. Aviation refuelling 1" trigger nozzle for use with Avgas or Jet A1, with internal check valve and 25 mm bore spout with 100 mesh strainer.

Operation. Manual deadman lever, no high level cut off.

Flow Rate. Up to 140 Litres/Minute.

Maximum Working Pressure. 5 Bar.

Materials Of Construction. Aluminium body, guard and inlet swivel, Stainless Steel and Acetal internals, Nitrile and Vulkollan seals.

Inlet Connection. Swivel type, threaded 1" BSPP male (BSPP female as an option).

Nett Weight. Approx. 1.3 Kg with spout fitted.

Accessories (to be ordered separately).

Bonding cable and clip, 1.2m or 2.0 metres long.

Alternative spout, collar type for Jet A1 selectivity.

Dust cap and spring loaded keep chain.

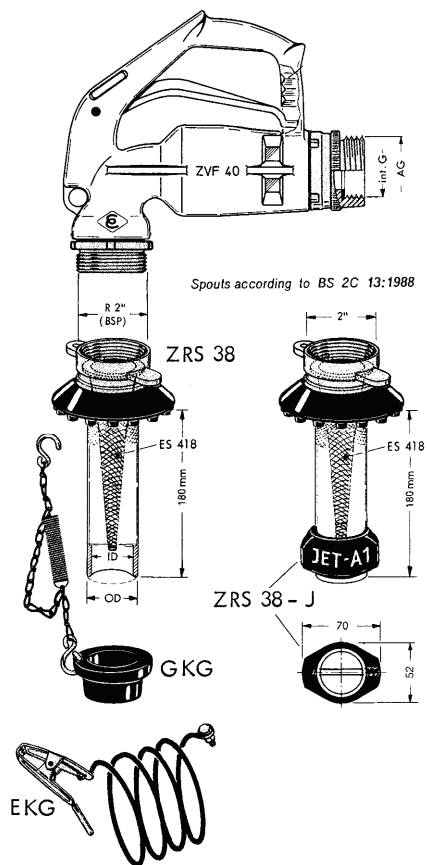

ZVF40. How To Order.

Quote part number 160ZVF40.1 for the basic nozzle, accessories must be ordered separately from the following list.

ZRS32 Spout, 38 mm outside diameter, 16000ZRS32.

ZRS38 Spout, 44 mm outside diameter, 16000ZRS38.

ZRS38J Spout, 44 mm outside diameter with 70 mm wide collar, 16000ZRS38J1.

ZRS38J Spout, 70 mm wide oval design, 16000ZRS38J.

GKG32 Dust Cap for ZRS32, with spring loaded keep chain, 16000GKG32.

GKG38 Dust Cap for ZRS38, with spring loaded keep chain, 16000GKG38.

GKG38J Dust Cap for ZRS38J, with spring loaded keep chain, 1600GKG38J.

EKG plastic coated Stainless Steel bonding wire and Brass clip/plug.

1.2m long, 160EKG1200.

2.0m long, 160EKG2000.

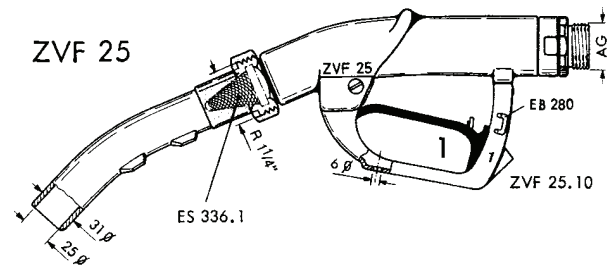

GKG 25

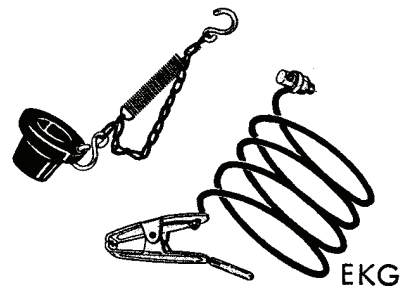

SG 1"

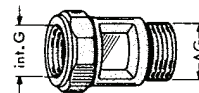

ZVF25. How To Order.

Quote part number 1600ZVF25.10 for the basic nozzle with spout, accessories must be ordered separately for the following list.

GKG Dust Cap with spring loaded keep chain, 16000GKG25.

EKG plastic coated Stainless Steel bonding wire and Brass clip/plug.

1.2m long, 160EKG1200.

2.0m long, 160EKG2000.

SG1" Sight Glass, threaded 1" BSPP male by 1" BSPP female, 160000SG1.

Jet A1 selective spout instead of standard 25 mm spout, 16000ER339.

ZVF25/ZVF40 Pressure Loss.

