

**Carter®**

Helicopter In-Flight Refueling (HIFR) Nozzle

Model 64048



**EATON**

*Powering Business Worldwide*

**Aljac**

# Design Concepts

Eaton's Carter product line includes a number of aircraft pressure fueling nozzles. Model 64048 Pressure Fueling Nozzle is used for Helicopter In-Flight Refueling (HIFR) operations from US naval vessels. These nozzles are identical in appearance to US Army Closed Circuit Refueling (CCR) nozzles but regulate pressure at 45 psig (3.102 bar) instead of 15 psig (1.034 bar) for the Army nozzles. This difference in pressure regulating settings is because U.S. naval aircraft are designed to allow fueling at pressures up to 55 psig, while U.S. Army aircraft are

designed to allow fueling at either 15 psig (1.034 bar) or 55 psig (3.792), depending on the model. These nozzles are designed to connect to helicopters and perform hot refueling operations while hovering above ships. The nozzle is designed to connect to helicopters that have receptacles in accordance with U.S. Army drawing C13219E0479 or equivalent. The nozzles provide "tight fill" capability and limits system pressure. Positive interlock is provided.

## Features

- Standard nozzles meet latest US Navy requirements in accordance with the Aircraft Refueling NATAOPS Manual, NAVAIR 00-80T-109 and Helicopter Procedures for Air Capable Ships, NAVAIR 00-80T-122
- Meets human engineering standards
- Positive interlock system — nozzle will not open unless connected and closes automatically when disconnected
- Lightweight and rugged construction
- Limits pressure to helicopter adapter to 45 psi (3.102 bar) regardless of inlet pressure
- Standard meets tan color requirements
- Standard Model 64048 meets Type I, Class A requirements, with 100-mesh strainer and 2-inch female camlock inlet
- Optional, Type I, Class B nozzle, comes with 100-mesh strainer, non-valved unisex coupling and dust cap (standard nozzle only)

## Ordering Data

The basic Model 64048 is a Type I, Class A CCR nozzle that meets tan color requirement, with 2-inch female camlock inlet, 100-mesh strainer and 15-foot bonding cable. The nozzle may be ordered with various options by adding one or more of the letters as listed in the table below. Some options must be ordered, as noted, to achieve a complete unit.

The basic unit weighs 9.0 lbs (4.082 kg).

Option Letter	Description	Comments
A	Nozzle (HIFR) Closed Circuit Refueling, same as 64048 except inlet terminates in 1½-inch female NPT with bonding cable. (No inlet coupling or strainer)	Cannot combine with B, C or D
B	Nozzle (HIFR) Closed Circuit Refueling. Includes 100-mesh screen housing, 2-inch unisex coupling (non-valved) in accordance with MIL-C-53071, color tan and 15-foot bonding cable	Option B replaces camlock inlet fitting with unisex coupling (non-valved) in accordance with MIL-C-53071. Cannot combine with A, C, D or Z.
C	64048 nozzle (HIFR) with male camlock fitting — 2-inch female NPT inlet	Inlet is 2inch NPT female pipe thread. Cannot combine with A, B, C or Z.
D	64048 nozzle (HIFR) with male adapter to mate 61154 female half for interchange with underwing nozzles. Includes 100-mesh strainer	For underwing nozzle interchange connection. Cannot combine with A, B, C or Z.
E	Nozzle (HIFR) Closed Circuit Refueling. Includes 100-mesh screen housing, 2-inch unisex coupling (valved) in accordance with MIL-C-53071, color tan and 15-foot bonding cable	E option replaces camlock inlet fitting with unisex coupling (valved) in accordance with MIL-C-53071. Cannot combine with A, C, D or Z.
G	Changes color to green when used with basic unit and Options B, C or D	Use Option G with basic part number or Options B or C
Z	Nozzle (HIFR) Closed Circuit Refueling in accordance with MIL-PRF-52747, Type I and II. Includes 100-mesh screen housing terminating in a 2-inch female camlock fitting with plug and 15-foot bonding cable.	Option Z cannot be used with Options A, B, F or G. Green exterior color is standard (not available in tan).

### Examples:

64048BG Nozzle (HIFR) Closed Circuit Refueling nozzle, green color, with non-valved unisex coupling per MIL-C-53071 inlet, 100-mesh strainer and 15-foot bonding cable

Dimensions shown  
in inches (millimeters)

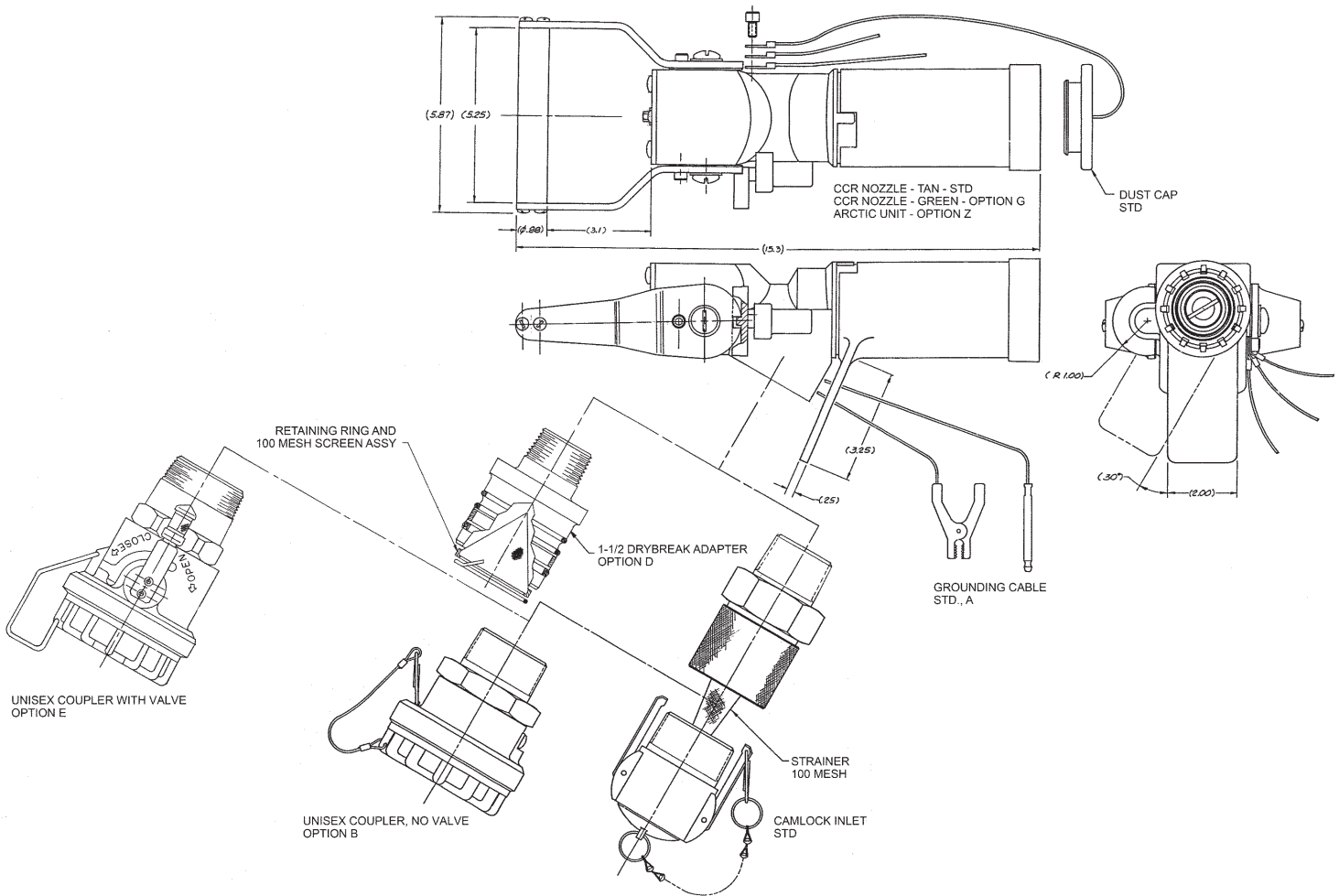

**Eaton**  
**Aerospace Group**  
**Fluid & Electrical Distribution Division**  
**9650 Jeronimo Road**  
**Irvine, California 92618**  
**Phone: (949) 452 9500**  
**Fax: (949) 452 9992**  
**E-mail: [groundfueling@eaton.com](mailto:groundfueling@eaton.com)**