

APOLLO BRONZE DEADMAN BALL VALVE

- ◆ **SPRING CLOSE OPERATION**
- ◆ **BRONZE CONSTRUCTION**
- ◆ **COMPACT ERGONOMICAL DESIGN**
- ◆ **ROBUST SPRING RETURN UNIT**

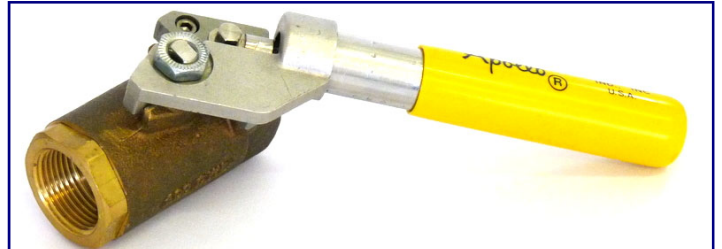

Introduction

With the increased need for operational safety and environmental awareness, in many applications the risks associated with inadvertently leaving a ball valve fully or partially open are now unacceptable. The “Deadman” operating principle is therefore required, where releasing the ball valve handle automatically causes the valve to close.

This has traditionally been achieved by fitting a clock type torsion spring box to a standard ball valve via tailor made mounting brackets, and has presented a number of problems. The torsion spring is prone to failure when abused, and the combination with a standard ball valve requires an excessive operating torque which in turn imparts unusual pipework loadings. Also, because the valve and spring return units have been designed in isolation, the brackets are usually complex and themselves prone to failure. The overall system is expensive and bulky, with the spring return unit often costing more than the valve itself.

However, a practical and inexpensive alternative solution is now available.

The Apollo Deadman Ball Valve

The Apollo Deadman Handle and Series 71 Ball valve have been designed in parallel to produce a workable solution to the problems outlined.

The Series 71 Ball valve is constructed from Bronze with a Brass ball and stem, the seats and seals are reinforced PTFE. The ball is Chrome plated and the stem is of a blow out proof design. The end connections are threaded NPT female. However, the valve also has an integral mounting pad to secure the Deadman Handle directly, without the need for complex, expensive, and unreliable brackets.

The Deadman Handle is of all Stainless Steel construction and utilises an adjustable compression spring fitted inside the handle itself., and the spring load can be quickly set on site to give the optimum operating torque. The handle is plastic covered and is 25 mm in diameter to give comfortable hand grip and easy operation.

The combination of handle and valve amounts to the most reliable, most compact and most cost effective answer to the Deadman Ball Valve requirement.

Layout

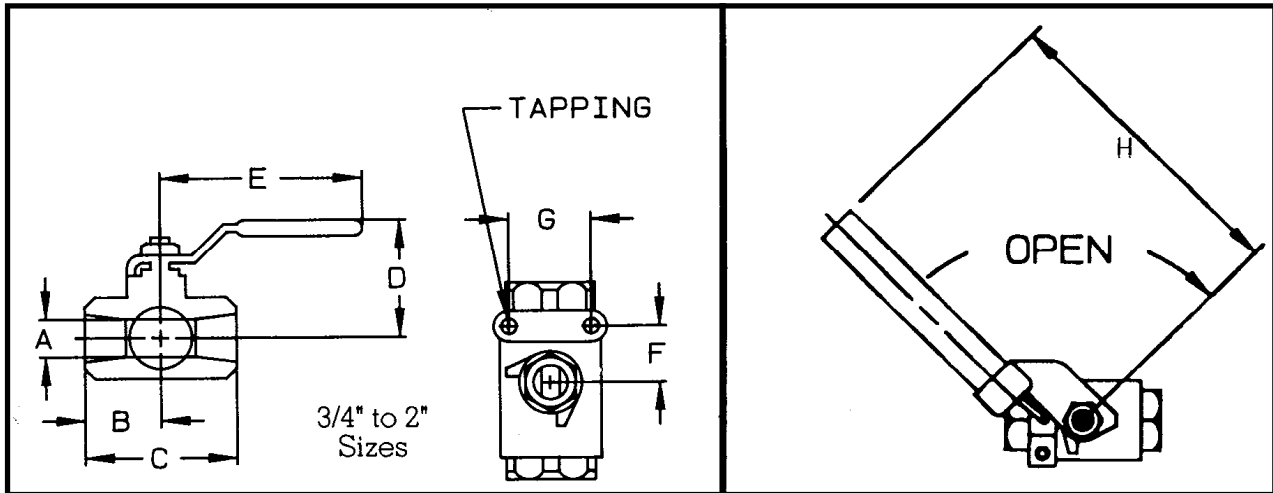

Overall Dimensions

Size	Dimensions (mm)								Cv	Part Number	
	A	B	C	D	E	F	G	H		(NPT ends)	(BSPP ends)
1/4"	9.4	26.2	52.3	44.5	98.3	12.7	28.5	177.8	6.8	0607150101	-
3/8"	9.4	26.2	52.3	44.5	98.3	12.7	28.5	177.8	6.8	0607150201	-
1/2"	12.7	28.4	57.2	46.0	98.3	12.7	28.5	177.8	9.8	0607150301	06071503P01
3/4"	17.3	38.1	76.2	53.8	123.7	22.1	34.8	177.8	25	0607150401	06071504P01
1"	22.1	42.7	85.6	57.2	123.7	22.1	34.8	177.8	35	0607150501	06071505P01
1.1/4"	25.4	50.8	101.6	66.6	139.7	23.6	38.1	228.6	47	0607150601	-
1.1/2"	31.8	55.4	111	77.5	203.2	23.6	38.1	228.6	81	0607150701	06071507P01
2"	38.1	69.9	139.7	82.3	203.2	23.6	38.1	228.6	105	0607150801	06071508P01

Technical Specification

Design: Two piece reduced bore, blow out proof stem, adjustable gland packing.

Pressure: 600psi WOG rating.

End Connections: NPT or BSPP female.

Handle: Spring close (deadman).

Material:

Valve body: Bronze B584-C84400.

Ball and stem: Brass B16, ball Chrome plated.

Deadman handle components: Stainless Steel.

Seals: Reinforced PTFE.