

TW FLEXIBLE EXPANSION JOINTS

- ◆ PROVIDES FLEXIBILITY IN THE PIPEWORK SYSTEM
- ◆ ALLOWS FOR PIPEWORK EXPANSION, VIBRATION AND MISALIGNMENT
- ◆ SUITABLE FOR PRESSURE OR SUCTION DUTY
- ◆ ELECTRICALLY CONDUCTIVE
- ◆ CAN BE FITTED BETWEEN TANK AND PIPEWORK



Introduction

In fluid handling systems it is often necessary to make allowance for pipework expansion, vibration and slight misalignment. This is particularly recommended where a large flexibly mounted component, such as a storage tank, or a vibrating mass, such as a pump or hose reel, is connected to the system. This flexibility is normally achieved by fitting a flexible expansion joint.

Description

The Elaflex TW Flexible Expansion Joint consists of a flexible centre section mounted between two flanges. The inner liner is Nitrile rubber which resists all light hydrocarbon products with less than 50% aromatics content, furnished with an electrically conductive Chloroprene cover for static charge dissipation. The flanges are forged Aluminium in accordance with the TW pattern which is commonly used on road tanks. Other flange configurations are available to special order, please consult our Sales Department.

The TW Flexible Expansion Joint can be connected to the mating flanges without the use of additional gaskets due to the overlapping profile of the rubber section. It is suitable for use

in pressure or vacuum applications, however, if it is used under high vacuum conditions we recommend that a Stainless Steel Vacuum Support Ring is fitted.

Aljac Fuelling Components holds stock of complete assemblies from 50 mm to 150 mm diameter, and also replacement centre sections.

Technical Specification

Type: Elaflex TW Flexible Joint, Yellow ring.

Construction: Seamless Nitrile rubber liner, rubberised Nylon reinforcing layer, Chloroprene CR cover, forged Aluminium flanges, Stainless Steel Vacuum Support Ring.

Properties:

Electrical Resistance: Between one thousand and one million Ohms.

Maximum Working Pressure: 10 Bar.

Test Pressure: 16 Bar.

Maximum Working Temperature: 90°C.

How To Order

Select the size and duty and contact Aljac Fuelling Components with the relevant part number from the table overleaf.

Dimensions

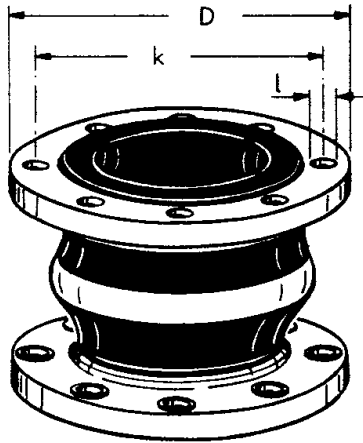

WARNING. It is essential that the system builder observes the correct installation methods and follows the manufacturers installation recommendations. Copies are available on request.

Description	Size (mm)	Part Number	Flange Dimensions (mm)			Weight (kg)	Maximum Vacuum (m water)
			D	k	I		
ERV50 with Vacuum Support Ring	50	70ERV050TWY1	154	130	8 x 11.5	1.25	10
ERV80 with Vacuum Support Ring	80	70ERV080TWY1	154	130	8 x 11.5	1.40	10
ERV100 with Vacuum Support Ring	100	70ERV100TWY1	174	150	8 x 14.0	1.70	10
ERV150 with Vacuum Support Ring	150	70ERV150TWY1	240	210	12 x 14.0	3.36	7

Installation and Allowable Movement

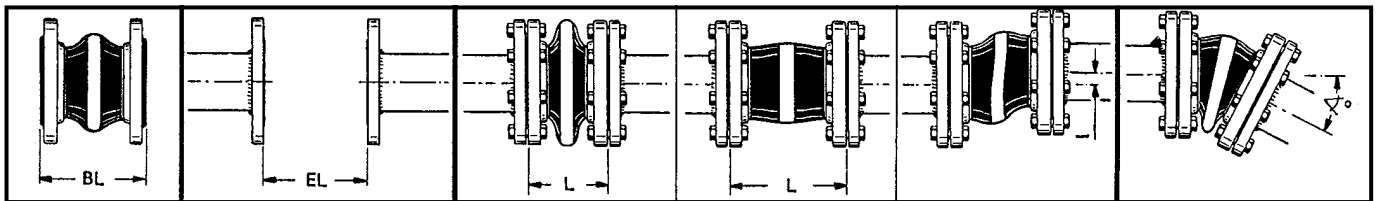

Free Length (mm)	Flange Face to Face Installation Length		Allowable Movement In Service (mm)			Angular Rotation (degrees)	Size (mm)
	Minimum	Maximum	Minimum Length	Maximum Length	Maximum Lateral Offset		
130 +5 -0	120	135	100	160	+30 -30	+30 -30	DN50
130 +5 -0	120	135	100	160	+30 -30	+30 -30	DN80
150 +5 -0	140	155	115	180	+30 -30	+20 -20	DN100
150 +5 -0	140	155	115	180	+30 -30	+20 -32	DN150