

ALUMINIUM BALL VALVES

- ◆ **COMPACT AND LIGHTWEIGHT**
- ◆ **FLANGE x FLANGE OR FLANGE x MALE THREAD ENDS**
- ◆ **2 INCH TO 4 INCH SIZES**
- ◆ **FULL BORE DESIGN, LOW PRESSURE LOSS**
- ◆ **STAINLESS STEEL BALL**
- ◆ **SPRING LOADED SEALS, SMOOTH OPERATION**
- ◆ **FULLY INTERCHANGEABLE WITH RENUS VALVES**



Introduction

For many years Aluminium ball valves have been the industry standard for fitment to aviation refuelling vehicles. The rugged, compact and lightweight design makes them the ideal choice for this application which requires the use of the very highest quality equipment. Aviation refuelling vehicles need components with very compact envelope dimensions because space is often restricted due to the sheer amount of equipment which must be incorporated in order to ensure safe and efficient operations, and in this application weight is also at a premium for the same reason.

Description

Our Aluminium ball valve is a full bore fixed ball design and has an Aluminium Alloy body with a Stainless Steel ball and PTFE/Viton seats and seals, so it is ideal for handling aviation fuels. The full bore design minimises the pressure loss through the valve, which is critical for aviation refuelling where flow rates of up to 4000 Litres/Minute are commonplace in order to minimise aircraft turnaround times.

The operating lever can be indexed which allows the valve operation to be from the 0 to 90 degree positions, or from 45 to 135 degree positions. This

is very useful when arranging the equipment position on the refuelling vehicle because it offers the vehicle designer much more flexibility when considering possible pipework layouts. The valve is fitted with an easily replaceable stop disc which ensures accurate positioning of the ball in both the open or closed positions.

The valve has a working pressure of 10 Bar, which is in line with current refuelling vehicle specifications, and has a 21 Bar test pressure which allows the hoses to be pressure tested insitu against the closed valve so the hoses do not need to be removed for regular pressure testing.

NOTE. The system pipework should be vented during hose pressure testing in order to protect the system against inadvertent pressure build up in the event of leakage past the valve seals.

The valves are available with TW flanges both ends, or with a TW flange/BSPP male thread combination. The valves are commonly used as hose isolation/flow control valves, as inlet isolation valves on hydrant dispensers, and as external suction or tank rapid drain valves on refuelling tankers. The valves are also fully dimensionally interchangeable with the equivalent Renus valves.

Special Seal Design

Our valve has a unique seal design. The seal is spring loaded against the ball (as shown) with a disc spring, and the result is that the valve operating torque does not vary as the temperature changes (which is a known weakness with competitor's valves). In addition, when combined with the smooth surface finish of the Stainless Steel ball, the difference between the static 'break out' torque and the dynamic operating torque is very low, which means that the valve handle is very easy to operate.

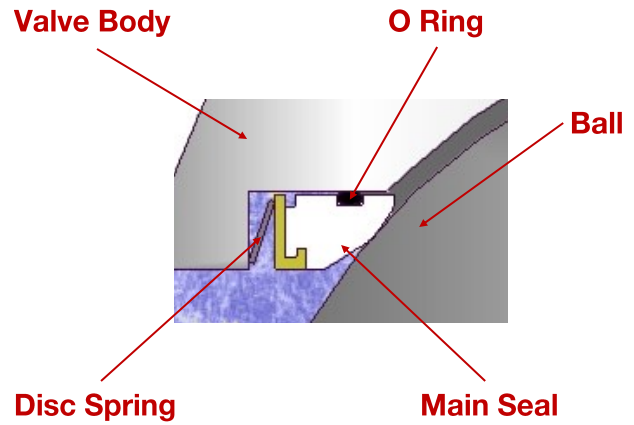

Dimensions Type 420

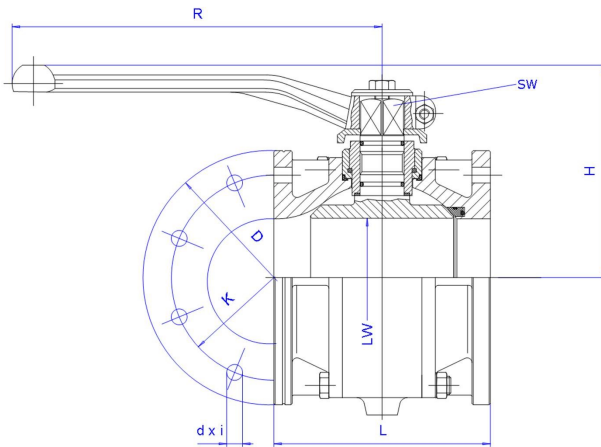

Dimensions Type 430

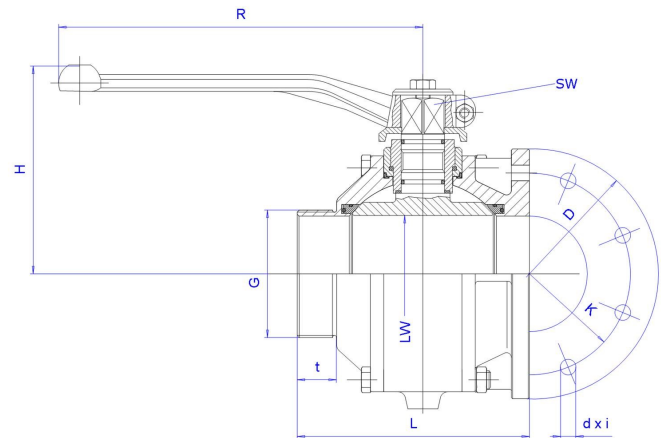

Size	LW	L	D	K	d x i	H	R	SW	Wt. Kg.
DN50	50	142	154	130	11.5 x 8	130	250	17	4.5
DN65	64	160	154	130	11.5 x 8	140	270	19	6.9
DN80	78	140	154	130	11.5 x 8	150	270	19	8.0
DN100	97	180	174	150	14.0 x 8	175	330	27	14.2

Size	LW	L	D	K	d x i	G	t	H	R	SW	Wt. Kg.
DN50	50	140	154	130	11.5 x 8	2"	20	130	250	17	3.9
DN65	64	158	154	130	11.5 x 8	2.1/2"	20	140	270	19	6.4
DN80	78	160	154	130	11.5 x 8	3"	24	150	270	19	7.9

All dimensions in Millimetres

How To Order

Valve Type	Size	End Connections	Part Number
420/50	2"	Flanged TW1 both ends	0284205008
420/65	2.1/2"	Flanged TW1 both ends	0284206508
420/80K	3"	Flanged TW1 both ends	02842080K8
420/100	4"	Flanged TW3 both ends	0284201008
430/50	2"	Flanged TW1 x 2" BSPP male thread	0284305008
430/65	2.1/2"	Flanged TW1 x 2.1/2" BSPP male thread	0284306508
430/80	3"	Flanged TW1 x 3" BSPP male thread	0284308008

Specification

Sizes: 2 inch, 2.1/2 inch, 3 inch, 4 inch (full bore).
Operation: Lever with removable stop disc.
Body and Flange Material: Aluminium Alloy GK -AlSi12+Mg.
Ball Material: Stainless Steel 1.4301.
Stem Material: Stainless Steel.
Ball Seats: Glass filled PTFE.
Stem Bearing: PTFE.
O Rings: Viton.
End Connections:
 420 Series: TW flanges to DIN28460 both ends.
 430 Series: TW flange to DIN28460 x BSPP male thread to DIN259.
Maximum Working Pressure: 10 Bar.
Test Pressure: 21 Bar.