

# SPRING REWIND STATIC BONDING REEL

- ◆ **AUTOMATIC REWIND AT A CONTROLLED SPEED**
- ◆ **HEAVY DUTY DESIGN, LONG SERVICE LIFE (TESTED TO 5000 CYCLES)**
- ◆ **COMPACT AND LIGHT WEIGHT**
- ◆ **FULLY ENCLOSED SPRING AND LATCH MECHANISM**
- ◆ **WEATHER RESISTANT FINISH**
- ◆ **PERMANENTLY LUBRICATED BEARINGS**

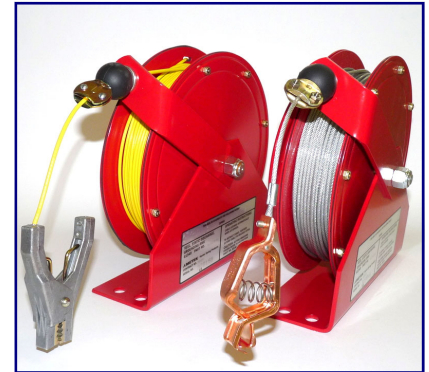

## Introduction

It is accepted practice to bond adjacent system components when transferring flammable liquids or powders at high flow rates by using a bonding reel and cable. Spring rewind reels are favoured by the military, but have traditionally suffered from poor reliability under extreme service conditions, particularly when subjected to operational abuse.

The US Military Specifications MIL-R-83325 and A-A50696 (replaces MIL-R-83232) are therefore regarded as the definitive performance standards for spring rewind static earthing reels. Aljac Fuelling Components is now able to offer the Ametek Spring Rewind Static Bonding Reel, which meets, and indeed exceeds the requirements of the US Military Specifications.

## Description

By using the SPIR'ATOR spring in preference to the more commonly found power type spring, our Reel is approximately 1/3 of the size and 1/2 the weight of the other reels which conform to the US Military Specifications.

The cable is pulled out against the spring and a latch mechanism locks the drum in place.

Retraction is initiated by a slight pull on the cable which releases the latch. During retraction the speed is automatically regulated to between 0.6 and 2.0 metres per second by a unique centrifugal brake device, and the design is such that it should not be necessary for the operator to attend the rewind operation. This is not a requirement of the US Military Specifications but it is an additional benefit that this reel offers over many others. However, we recommend that the operator 'walks' the cable back in as an additional safety precaution and to prolong service life.

The reel is constructed from plated Steel components with a stoved on red external paint finish for weather resistance, and the drum has a gasketed seal to protect all internal working parts from corrosion due to moisture ingress. The reel bearings are permanently lubricated.

As standard the reel is fitted with clear plastic coated Galvanised Steel cable and a Mueller type clip. Three sizes of reel are available with cable lengths of 15, 22 and 30 metres. However, the reels can be supplied with no cable fitted, or with alternative cable and clip type on request. Please contact our Sales Department for details.

## Dimensional Drawing

Inches (Millimeters)

ML2930-15 & ML2930-14

ML3416-2

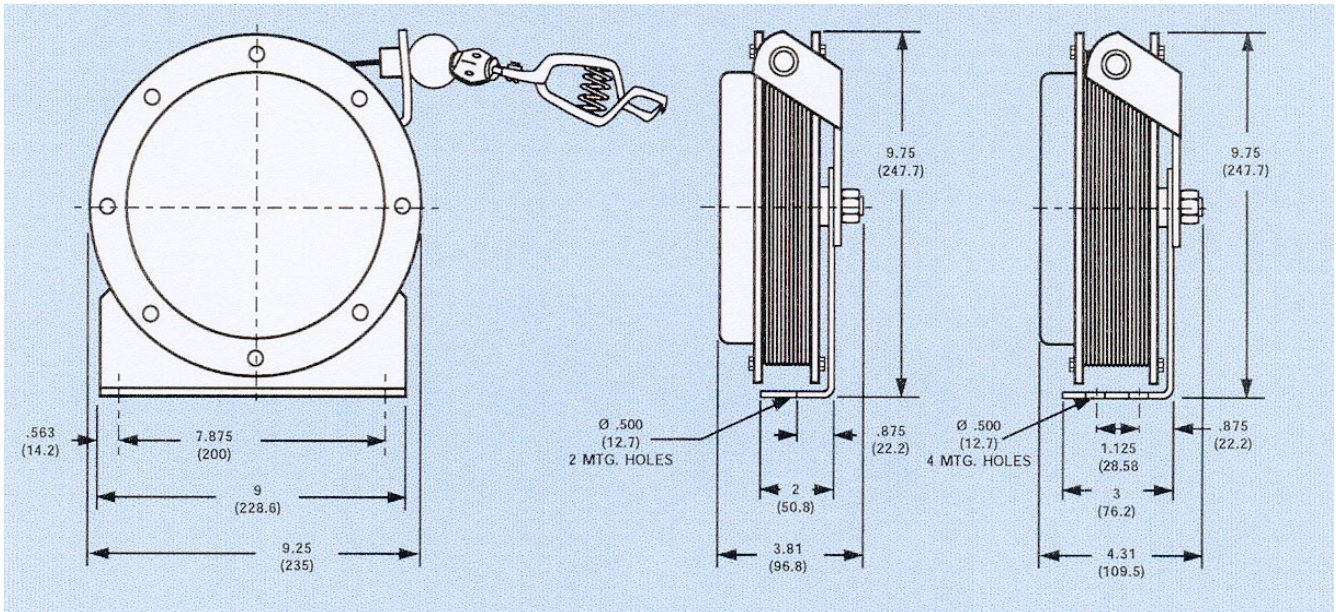

## How to Order

Model	Part Number	Cable Length	Nett Weight Approx. (kg)
ML2930-15	<b>0100215011</b>	15 metres	7.0
ML2930-150	<b>0100215010</b>	None fitted	5.0
ML2930-14	<b>0100215021</b>	22 metres	9.0
ML2930-140	<b>0100215020</b>	None fitted	5.0
ML3416-2	<b>0100215031</b>	30 metres	10.5
ML3416-20	<b>0100215030</b>	None fitted	6.0

## Detailed Specification

**Reel Type:** Spring rewind, with hold on latch, automatic rewind speed control and adjustable cable guide.

**Materials of Construction:** Plated Steel drum and mounting bracket.

**Finish:** Stoved on red paint to MIL STD808, film designation DG.

**Standard Cable:** 7x7 Galvanised Steel core to 2.2 mm diameter, clear plastic coated to 3.2 mm diameter.

**Standard Clip:** Mueller 21C Copper, 4 inch size.

**Electrical Resistance:** 10 Ohms maximum clip to mounting bracket with standard cable and clip.

**Operating Life:** Type tested to 5000 cycles.

**Cable Retraction Speed:** 0.6 to 2.0 metres per second.

**Operating Temperature Range:** Minus 54°C to plus 52°C.

**Storage Temperature Range:** Minus 62°C to plus 72°C.