

# UNDER HYDRANT BALL VALVE

- ◆ **COMPACT AND ROBUST**
- ◆ **FULL BORE DESIGN, MINIMAL PRESSURE LOSS**
- ◆ **EXTERNAL GEARBOX FOR EASE OF OPERATION**
- ◆ **OPERATED FROM A STANDING POSITION**
- ◆ **FIRESAFE TO API 607**
- ◆ **6 INCH STONEGUARD STRAINER**
- ◆ **EUROPEAN MANUFACTURED, FULL MATERIAL CERTIFICATION**

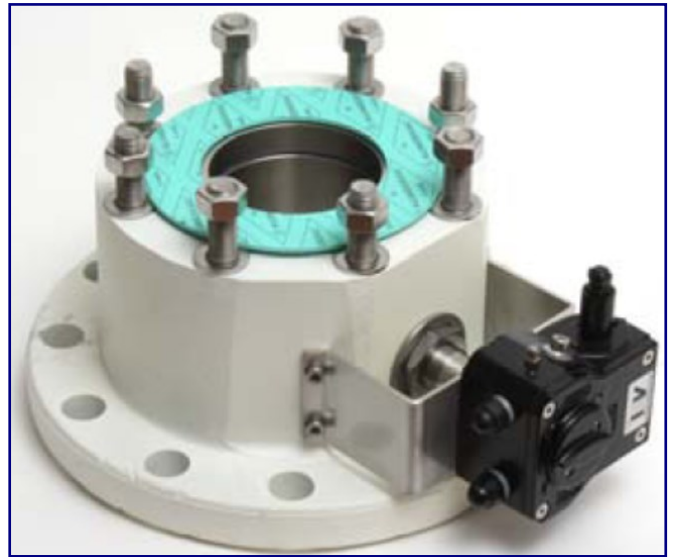

## Introduction.

Aviation fuel hydrants are pressurised piping systems which run underground at the major airports. The hydrant pit valve is the primary point of connection between the fuel hydrant and the refuelling vehicle (hydrant dispenser), so it is a critical point in the fuel delivery system. In the past it was common practice for the hydrant pit valves to be connected directly onto the fuel hydrant with either a 4 inch or 6 inch flange. However, with this arrangement, in the event of the hydrant pit valve leaking internally or to atmosphere and needing to be isolated from the pressurised hydrant, or if major maintenance requiring removal of the hydrant pit valve is required, it is necessary to isolate a section of the hydrant which means that section cannot be used.

The Aljac Under Hydrant Valve is used in conjunction with the current, shorter design of hydrant pit valves (such as Eaton's Carter® model 60554) and it addresses this problem. The Under Hydrant Valve is installed between the hydrant pit box and the hydrant pit valve, so it permits the safe isolation and removal of each individual hydrant pit valve from the hydrant. The Under

Hydrant Valve can therefore be closed if the hydrant pit valve is leaking or if major maintenance work needs to be carried out, without the need to close down the complete section of the hydrant line. This of course allows the hydrant to remain in operation while the problem valve is removed and overhauled.

## Description.

The Aljac Under Hydrant Valve is a 6 inch by 4 inch full bore ball valve designed for installation between the hydrant pit box and the hydrant pit valve. It is manually operated by a 970mm long handle through an externally mounted right angle gear box, which allows the operator to open and close the valve from a standing position without reaching into the hydrant pit box.



The Aljac Under Hydrant Valve is also supplied with an integral flat perforated plate stoneguard strainer which is fitted inside the inlet connection flange using a securing clip.

## Dimensions.

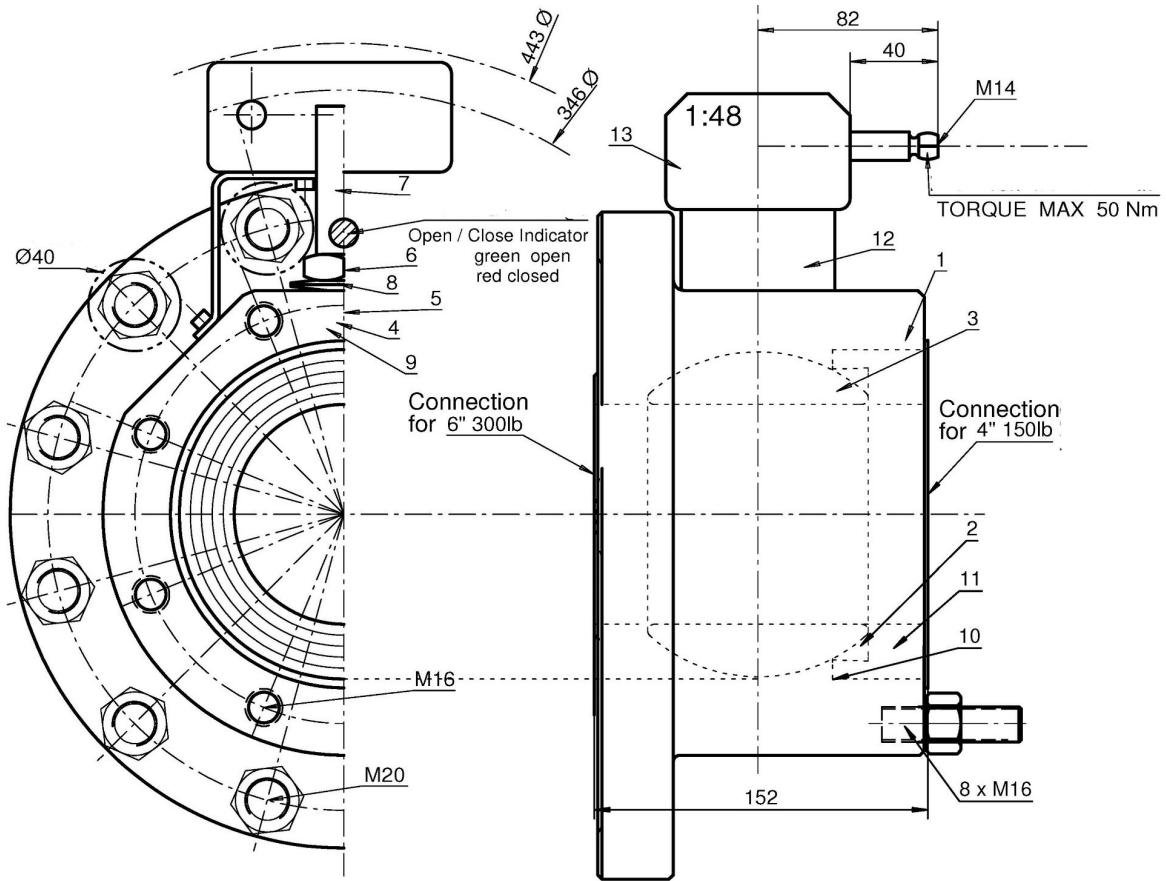

## Specification.

**Design Pressure:** 50 Bar.

**Design Temperature:** Minus 25 to plus 80 degC.

**Internal and External Coating:** To MIL-PRF-4556F, 200 Micron film thickness.

**Maximum Gearbox Input Torque:** 50Nm.

**Firesafe Test:** API 607 6th edition.

**Inlet Flange:** To mate with 6 inch ANSI B16.5 300lb raised face hydrant pit box flange.

**Outlet Flange:** To mate with 4 inch ANSI B16.5 150lb flat face hydrant pit valve flange.

**Studs, Nuts and Washers:** 8 off M16. Stainless Steel.

**Gasket:** 4 inch IBC Klingersil (included).

**Operating Handle:** **Supplied loose, not included with the valve.** 970mm long with 250mm diameter hand wheel.

**Stoneguard Strainer:** Fitted inside the inlet flange. 1.5mm thick Stainless Steel flat plate. 5mm diameter holes on an 8mm pitch spacing.

## How To Order.

Simply quote the following part numbers:-

**EW00001210:** Aljac Under Hydrant Valve.

**EW00001211:** Under Hydrant Valve Operating Handle (one per five valves recommended).

**EW00001212:** Under Hydrant Valve Soft Seal Kit.

**EW00001213:** Under Hydrant Valve Replacement Gearbox.

**EW00001214:** Under Hydrant Valve Full Overhaul Kit.

**EW00001215:** Under Hydrant Valve Special Servicing Tool.

Item	Name	Material
1	Body	GGG40.3
2	Seats #*	PTFE
3	Ball *	Stainless Steel
4	Packing Rings #*	Antistatic PTFE
5	Pressure Ring	Stainless Steel
6	Nut	Stainless Steel
7	Stem *	Stainless Steel
8	Cup Springs	Stainless Steel
9	O Rings #*	Viton TA
10	O Ring #*	Viton
11	Insert #*	Stainless Steel
12	Bracket	Stainless Steel
13	Gearbox	Steel
#Included in Soft Seal Kit.		
*Included in Full Overhaul Kit.		

Contact our Sales Department for Under Hydrant Valves with alternative flange face to face dimensions or low temperature materials.