

AVIATION FUEL HYDRANT PIT BOX

- ◆ **TWO PIECE ENVIRONMENTAL DESIGN**
- ◆ **COMPLIANT WITH BP STANDARD MECH 30**
- ◆ **MEETS THE REQUIREMENTS OF JIG STANDARDS**
- ◆ **EASY TO INSTALL**
- ◆ **OPERATOR FRIENDLY 18" OPENING**
- ◆ **OPTIONAL LIFT OFF LID**
- ◆ **OPTIONAL LAYFLAT HINGED LID**
- ◆ **SUPPLIED WITH INSTALLATION LEVELLING BRACKETS**
- ◆ **SUPPLIED COMPLETE WITH ALL ANCILLARY COMPONENTS**
- ◆ **AVAILABLE FROM STOCK**



Introduction

Aljac Fuelling Components Ltd has developed a Hydrant Pit Box to complement their range of equipment for installation on Airport Fuel Hydrants. The Hydrant Pit Box has been designed for ease of installation by contractors and ease of operation by fuelling operators. Aljac has incorporated options to ensure that the Hydrant Pit Box can be re-configured in situ after installation in order to accommodate changing requirements.

Description

The Aljac Hydrant Pit Box is a two piece environmental design ensuring that the integrity of the fuel Hydrant System is maintained in the event of ground shift or settlement post construction. Access into the Hydrant Pit Box is through a full 18 inches diameter opening in accordance with BP standard MECH 30 which provides unrestricted access even when the latest designs of Dual Air/ Lanyard Pilots are fitted to the Hydrant Pit Valve. The lid design has been carefully considered providing the option to install a traditional lift off lid with tether or a lay flat hinged design as is being specified by some airports. The Hydrant Pit Box is future proofed allowing

users to change between lift off lid or hinged lid with only minor changes which can be completed without any major work, a new lid is not required. This design also allows the lay flat hinged lid to be rotated after installation to ensure optimal positioning of the lid for fuelling operations. The standard lids are load tested and certified at a load of 900kN in accordance with BP MECH 30 standard. The design of the Pit Box will allow a lid conforming to EN 124-1 class F900 to be retrofitted if this standard is adopted in the future.

Specification

Inlet Pipe:	6 inch Schedule 40 Carbon Steel.
Pit Box Body:	Carbon Steel.
Flange:	6 inch ASME B16.5 300lb Carbon Steel.
Lid Weight:	17kg (standard MECH30 lid).
Lid Material:	Aluminium.
Lid Support Ring:	Aluminium.
Pit Box Coating:	Interzone 1000.
Pit Box Lining:	Interzone 954.
Pipe Lining:	Interline 850.

Dimensions

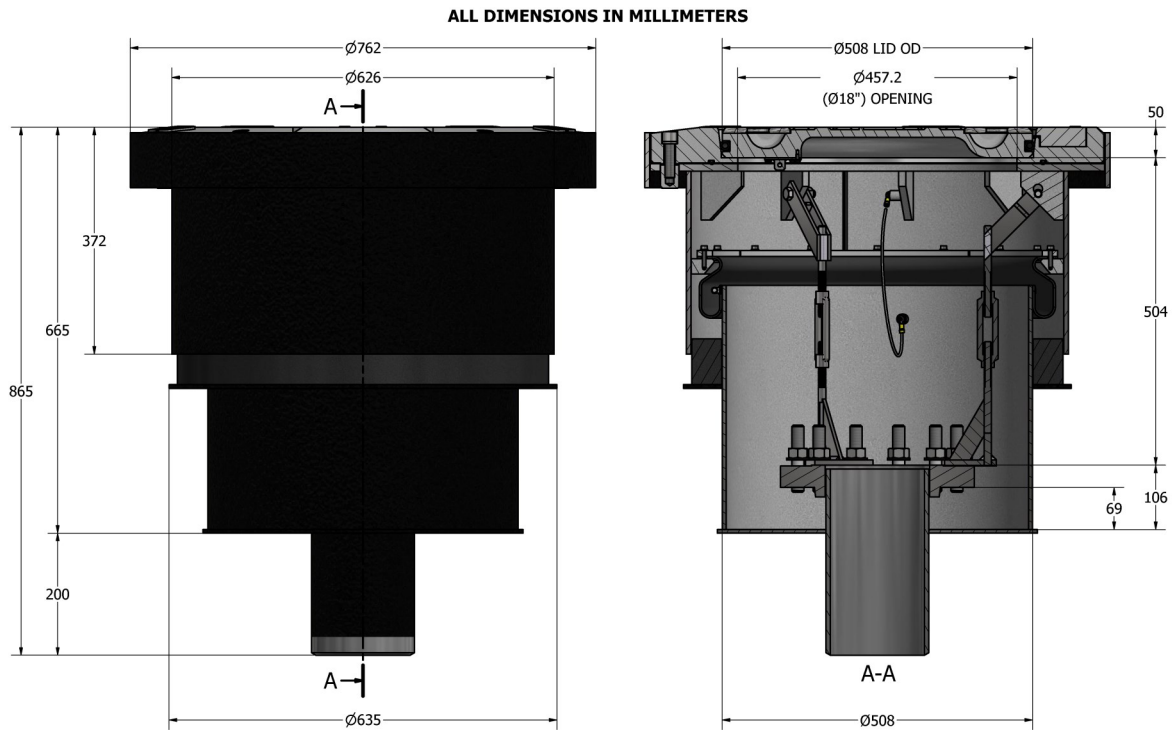

Hydrant Pit Box with Lift Off Lid

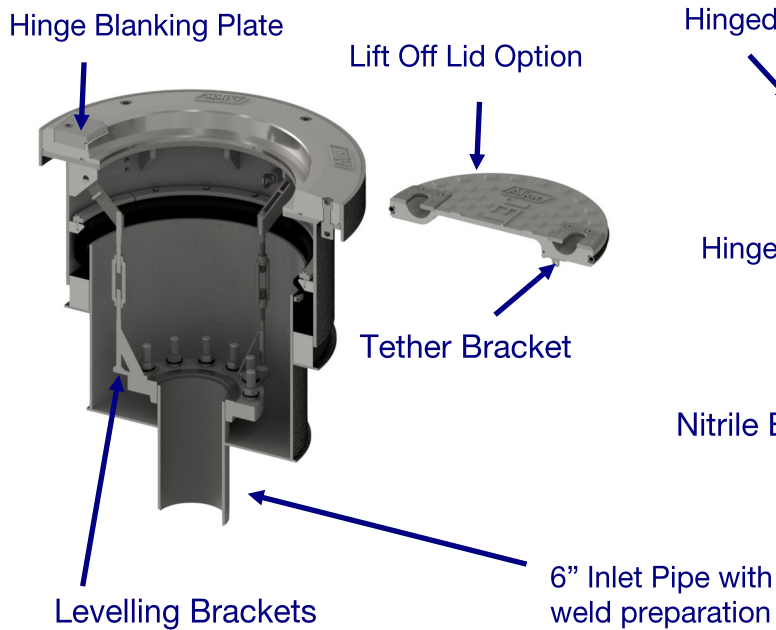

Hydrant Pit Box with Hinged Lid

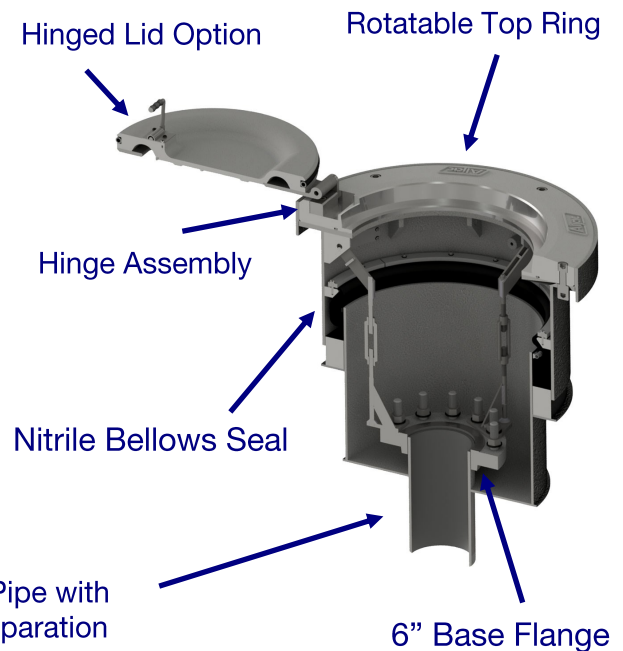

How To Order

Fuel Hydrant Pit Box with Lift Off Lid: **EW00002200**
 Fuel Hydrant Pit Box with Hinged Lid: **EW00002100**

Complementary Equipment in the Aljac Product Range

- Eaton's Carter® Hydrant Pit Valve model 60554.
- Aljac Under Hydrant Ball Valve.
- Aljac Under Hydrant 6" x 4" Spool Pieces.
- Aljac Under Hydrant Stone Guard Strainers.