

UNDERWING TO OVERWING ADAPTER

- ◆ **COMPACT AND LIGHTWEIGHT**
- ◆ **ROBUST ALUMINIUM ALLOY CONSTRUCTION**
- ◆ **HARD WEARING ALUMINIUM BRONZE FRONT SECTION**
- ◆ **SHOCK RESISTANT EASILY REPLACEABLE HANDLES**
- ◆ **OPTIONAL 1.1/2 INCH OR 2.1/2 INCH BSPP CONNECTION THREAD**



Introduction

On occasions it is necessary to temporarily extend the refuelling hose during aircraft pressure refuelling operations, but it is essential that this is accomplished with minimal fuel spillage.

The requirement may be to simply provide extra hose length, or to allow a system which is set up for pressure refuelling to be able to temporarily carry out open line overwing refuelling. To meet this need Meggitt developed the underwing to overwing adapters FCMY266 and FCMY267.

These units consisted of an ISO45 male half with handles fitted, and with either a 1.1/2 inch or 2.1/2 inch BSPP male thread. The existing pressure coupling could then be connected to the FCMY266 or FCMY267 which in turn could be fitted with an extension hose either terminating in a further pressure refuelling coupling or an open line overwing trigger nozzle.

Unfortunately these adapters have now been discontinued by Meggitt but Aljac Fuelling Components has produced its own versions of them. In addition, we have available a version with a 2.1/2 inch BSPP female thread, and we are able

to supply dust caps to suit

Our adapters are manufactured in high strength aluminium alloy and are furnished with a hard wearing high tensile aluminium bronze ISO45 front section. The handles are robust castings which provide excellent drop resistance and are easily replaceable by removing two screws.

How To Order

Simply quote the following part numbers:-

42FCMY2660: Adapter, ISO45 by 1.1/2 inch BSPP male thread, replaces Meggitt FCMY266.

42FCMY2670: Adapter, ISO45 by 2.1/2 inch BSPP male thread, replaces Meggitt FCMY267.

42FCMY2600: Adapter, ISO45 by 2.1/2 inch BSPP female thread.

42FCMY122M2: Dust cap, ISO45, Aluminium.

56DC2.5/30: Dust cap, ISO45, black Urethane.

Overall Dimensions

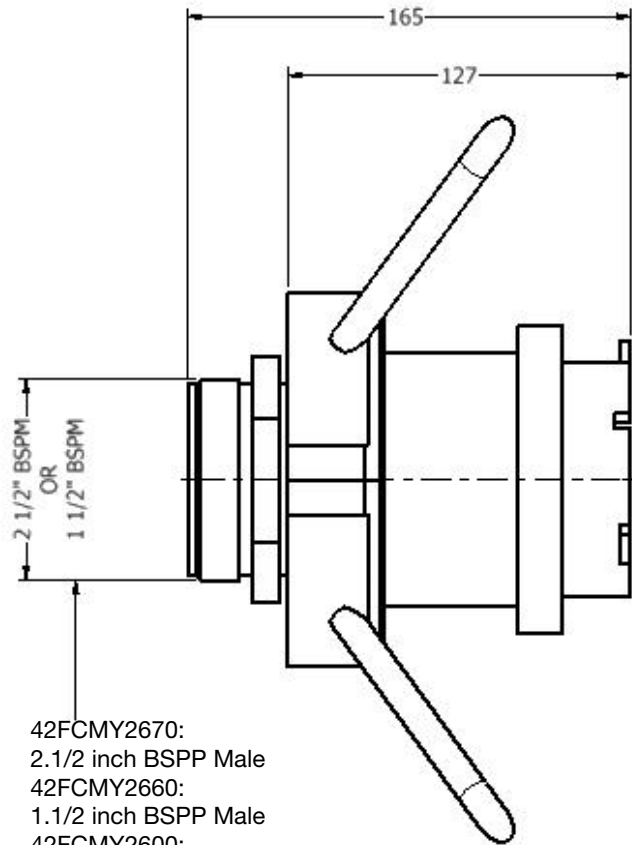

42FCMY2670:
2.1/2 inch BSPP Male
42FCMY2660:
1.1/2 inch BSPP Male
42FCMY2600:
2.1/2 inch BSPP Female

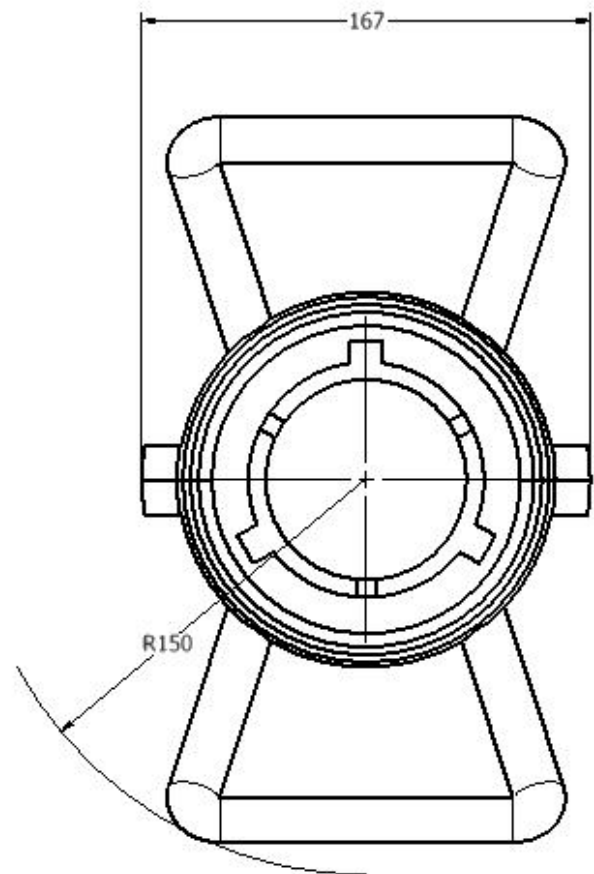

ALL DIMENSIONS IN MILLIMETERS UNLESS STATED OTHERWISE.

Specification

Nett Weight: 2.5 kg (not including dust cap).
Overall Dimensions: 165 x 167 x 300mm.
Maximum Working Pressure: 10.5 Bar.

Materials Of Construction

Body: Forged aluminium alloy.
Handles: Cast aluminium alloy.
ISO45 Connector: High tensile aluminium bronze.
Seals: Viton.