



# Design Concepts

Eaton's Carter product line includes Model 64800 Coupler, designed to supersede earlier Model 60700-1. It is used for air reference pressure control systems.

Many new features were incorporated into the design of Model 64800 at the request of long-time users of Model 60700-1, the standard of the industry for over 35 years.

## Features

- Mates all standard hydrant valves in accordance with API 1584
- Air/fuel sense ports parallel to outlet
- All ports with straight O-ring sealed threads
- 2½, 3 and 4 inch NPT or BSPP outlet threads available
- Air bleed under sealed screw
- Closing time adjustment accessible without removal of air port fitting
- Studs used for connecting lower half, reducing chance of over-tightening connecting fasteners

- Existing Model 60700-1 couplers can be retrofitted to gain most new features by changing only the elbow half
- Outlet of elbow flanged to accept various outlet male adapter fittings. Options to mate to older quick disconnects (QD) available, reducing maintenance costs if the male fitting is damaged.
- Optional carrying handles available. Transverse mounting standard, parallel optional. A second QD mounted handle is also available.
- Carriage affixed by studs. No special length bolts required, reducing chance of error when carriage is added in the field.
- Port to connect to hydrant provided on coupler — no special hose assembly required
- Parts common to 3 inch inline valves and Model 60700-1 used for less costly maintenance
- Lower half of coupler (connecting unit to hydrant) has not been changed

- System proof pressure of up to 450 psig (31.026 bar)
- Suitable for operating pressures of 200 psig (13.790 bar)
- Changes have been made without an increase in weight
- Outlet QD has thumb latches for easy disconnecting without use of any tools

## Operation Information

Model 64800 coupler is a direct spring loaded pressure control unit that is controlled by the air reference pressure provided from the vehicle system. It is nearly identical in design as the widely used Model 60700-1 with changes to improve operational handling and downsizing of the elbow to keep the weight the same. The slight increase in pressure drop, 3 psi (.207 bar) at 600 USgpm (2,271 l/min), caused by this is insignificant. A sealed screw outside of the air hose fitting provides closing time adjustment. A sealed screw is also used to bleed the unit of air.

## Technical Data

- Inlet mates any standard hydrant valve in accordance with API 1584
- Typical weight (Model 64800FW2L - see Ordering Data on page 3 for explanation of model number) — 34 lbs (15.42 kg)
- Pressure drop across mating Model 60554 hydrant valve and Model 648002L coupler— 24 psi (1.655 bar)
- Pressure drop across mating Model 60505 adapter and Model 648002L coupler — 24 psi (1.655 bar) at 1100 US gpm (4163 l/min)
- Operated by vehicle air reference pressure

## Envelope Dimensions

Dimensions shown in inches (millimeters)

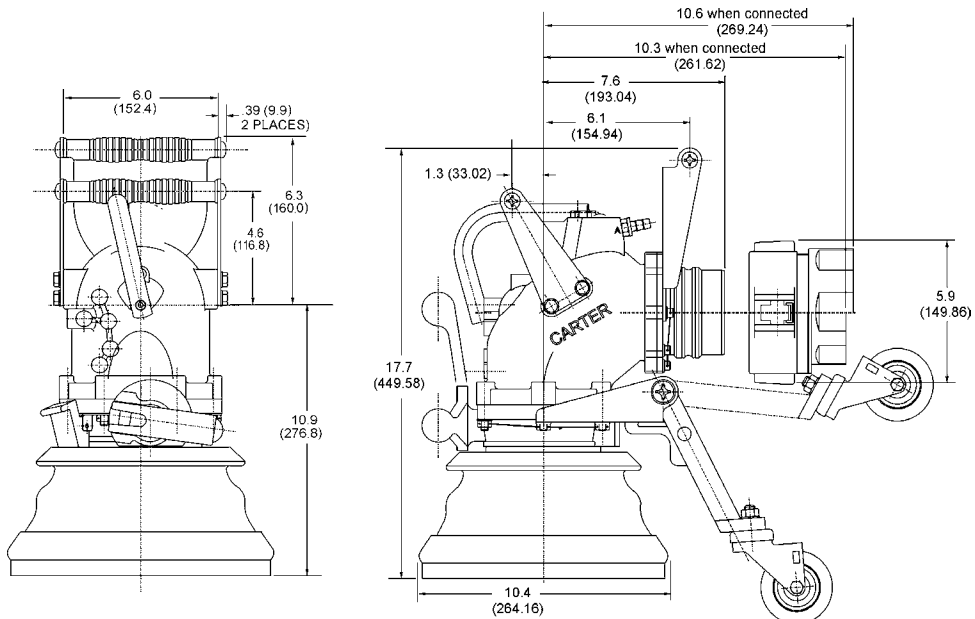

# Ordering Data

Various options are available on the Model 64800 coupler. The part number system is described to the right. The complete part number is comprised of four parts, as explained in the tables below.

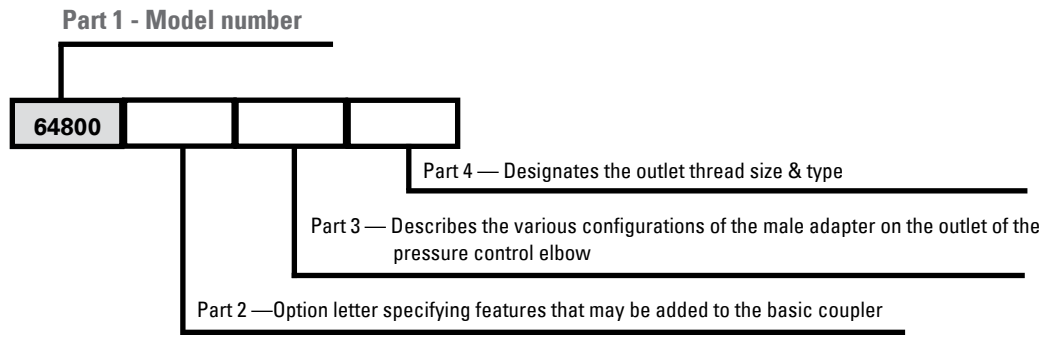

## Part 2

One or more of the options described at right may be added to the basic model number 64800 to obtain desired features.

Option Letter	Description	Option Letter	Description
B	Adds folding handle	J	Adds 3/8 inch hose barb fittings to both air and fuel sense ports
C	Adds product selection	R	Adds 90° elbow ¼ inch FNPT for air operated hydrant valve actuation
D	Adds lockwire to flange joint fasteners	W	Adds carriage assembly
E	Adds API style air/fuel QD	X	Adds safety clip to outlet disconnect (Option 2 only)
F	Adds hose barb fittings to air and fuel ports	Y	Adds handle assembly at outlet
H	Adds 3/8 inch FNPT fitting to both air and fuel sense ports	Z	Replaces standard transverse carrying handle at centerline of coupler with handle parallel to outlet (47214)

## Part 3

One of the options described at right must be added to determine the outlet male adapter configuration.

Option	Description	Option	Description
2	Adds 3 inch male adapter to mate standard thumb latched female QD.	4	Adds adapter to mate customer furnished Model 60600 (except option K) type QD
3	Adds 4 inch male adapter to mate 60700-1 style female QD		

## Part 4

One of the options described at right must be added to specify the outlet thread size and type.

Option Letter	Description	Option Letter	Description
H	Adds 2½ inch NPT thread female QD. Can be used only with Option 2 from Part 3.	N	Adds 4 inch BSPP thread female QD
K	Adds 2½ inch BSPP thread female QD. Can be used only with Option 2 from Part 3.	P	Adds 4 inch NPT thread female QD
L	Adds 3 inch NPT thread female QD	Q	Adds 2 inch NPT thread female QD. Can be used only with Option 2 from Part 3.
M	Adds 3 inch BSPP thread female QD	R	Adds 4 inch -8 NPSC thread female QD. Can be used only with Option 3 from Part 3.
		S	Adds 2 inch BSPP thread female QD. Can be used only with Option 2 from Part 3.

**Note:** If Part 4 is left blank, no female QD will be shipped. This is a proper designation when it is desired to use a Model 64800 to replace a Model 60700-1, 60600 or 60600-1 coupler. In this case, Part 3 must correctly designate the proper male adapter fitting.

### Examples:

- 64800BFGX2H Coupler with folding handle, hose barbs in all air/fuel ports, collar stop assembly, safety ring on QD, standard thumb latch QD with 2½ inch NPT threads
- 64800G3 Coupler with collar stop and male adapter fitting to mate to 60700-1 (no female QD provided)

**Eaton**  
**Aerospace Group**  
**Fluid & Electrical Distribution Division**  
**9650 Jeronimo Road**  
**Irvine, California 92618**  
**Phone: (949) 452 9500**  
**Fax: (949) 452 9992**  
**[groundfueling@eaton.com](mailto:groundfueling@eaton.com)**