

# HIGH CAPACITY CLOSED CIRCUIT SAMPLERS

- ◆ FULL VISUAL CHECK IN A CLOSED SYSTEM
- ◆ SUITABLE FOR TANK FARM USE
- ◆ 80 LITRE AND 160 LITRE CAPACITIES
- ◆ STAINLESS STEEL CONSTRUCTION
- ◆ LIFT AND TURN LID MECHANISM
- ◆ WATER DETECTION, DENSITY AND TEMPERATURE CHECK OPTIONS
- ◆ CLOSE COUPLED OUTLET BALL VALVE
- ◆ SPRING CLOSE INLET AND SAMPLE VALVES



## Introduction

For many years the Aljac range of Closed Circuit Samplers have led the way in the examination and quality checking of aviation fuel within a closed system. The benefits of Closed Sampling such as environmental acceptability, operational efficiency and safety, and minimal loss of product, have become widely recognised by fuel handling companies across the world. Our High Capacity Closed Circuit Samplers have been developed from our 4 Litre and 20 Litre units specifically for use in tank farms and other locations where large volume drain samples are required, and they share many of the innovative design features of their smaller cousins.

## Ancient History

Traditionally, the low points of large fuel storage tanks have been water purged and sampled by flushing fuel into a Stainless Steel bucket, followed by sampling into an open glass jar. The procedure evolved further when we developed our 4 Litre Closed Circuit Sampler. With this system, the flush volume is fed into a Stainless Steel side tank, followed by the glass jar sample being drawn into a 4 Litre Closed Circuit Sampler. This system has continued in use until the development of our High Capacity Closed Circuit Sampler.

## The Aljac High Capacity Closed Circuit Sampler

Our High Capacity Closed Circuit Sampler replaces both the Stainless Steel tank and the 4 Litre Sampler. It is connected directly to the main tank sample line, and the contents of both the sample line and tank low point are flushed into the glass vessel at a high flow rate through the spring close inlet valve. This allows the fuel velocity to be maximised and purges the low point more efficiently. It also ensures that any dirt and water will be seen, not just flushed into a side tank and ignored.

The unit has a polished Stainless Steel base incorporating a close coupled ball valve, which in conjunction with the tangential inlet and resultant fuel vortexing ensures that any contamination is highly visible to the operator. The unit is also available with hydrometer and thermometer pockets inside the glass tube for density/temperature checking, and with Shell Water Detector or Velcon Hydrokit test points fitted to the inlet pipework.

The inlet and outlet are flanged and there is a sample point in the outlet pipework fitted with a spring close ball valve. The complete unit is mounted onto a Stainless Steel support frame.

## General Arrangement Drawing

## Parts List

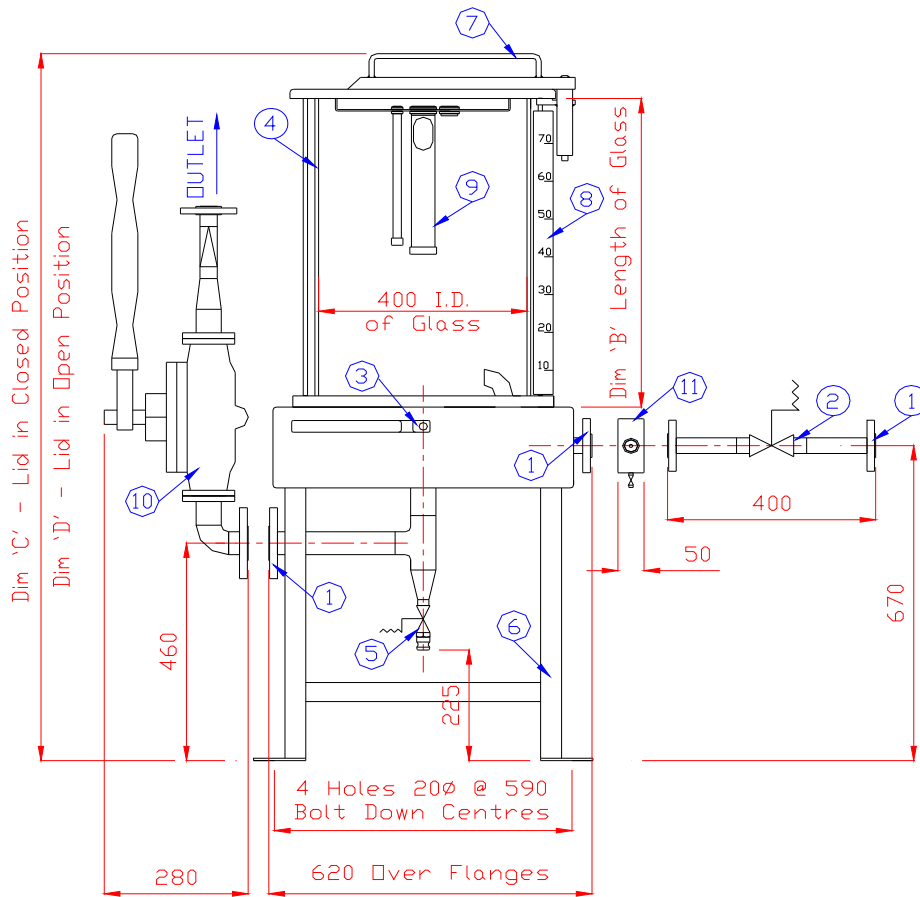

1. Inlet flanged 1" ANSI 150lb RF, outlet flanged 1.1/2" ANSI 150lb RF.
2. Conbraco 1" spring closed inlet ball valve.
3. Integral close coupled 1.1/2" bore outlet valve.
4. Borosilicate glass tube, 400mm inside diameter.
5. Conbraco 1/2" spring closed manual sample valve with Kamlok drain point and cap.
6. Stainless Steel support frame.
7. Easy access lift and turn lid.
8. Graduated scale (option).
9. Hydrometer and thermometer tubes (option).
10. Semi rotary emptying pump with non return valve (option).
11. External Shell Water Detector or Velcon Hydrokit fitting (option).

## Overall Dimensions

Capacity	Dimension B	Dimension C	Dimension D	Shipping Weight
80 Litres	640 mm	1500 mm	1525 mm	160 Kg approx.
160 Litres	1280 mm	2140 mm	2165 mm	175 Kg approx.

## Detailed Specification

**Working Capacity:** 80 Litres or 160 Litres.

**Material Of Construction:** Toughened Borosilicate Glass tube. Stainless Steel support frame, base, top section, inlet and outlet pipework.

**Inlet Connection:** Flanged 1" ANSI B16.5 150lb raised face.

**Outlet Connection:** Flanged 1.1/2" ANSI B16.5 150lb raised face.

**Inlet Valve:** Conbraco Apollo 1" Stainless Steel spring closed ball valve.

**Manual Sample Valve:** Conbraco Apollo 1/2" Stainless Steel spring closed ball valve with Kamlok male fitting and dust cap.

**Bolting Down Points:** 4 holes 20mm diameter.

## How To Order

Specify the size: 80 Litres. **Part number:**

**6007333201** or 160 Litres. **Part number:**

**6007333301** and call up any of the following options:

Hydrometer and thermometer pockets. **Part number: 6007333603.**

Shell Water Detector. **Part Number:**

**6007333601** or Velcon Hydrokit point. **Part number: 6007333602** fitted to the inlet pipework.

Semi rotary manually operated emptying pump and non return valve. **Part Number:**

**6007333605.**

Graduated Stainless Steel scale. **Part Number: 6007333606.**

If there are any features or additional items which you require, or if we can assist you with the design of your closed sampling system please contact our sales department.