

LARGE HUB BONDING CABLE REEL

- ◆ LARGE HUB FOR LESS FLEXIBLE CABLES
- ◆ COMPACT AND LIGHTWEIGHT
- ◆ ROBUST STAINLESS STEEL CONSTRUCTION
- ◆ IMPROVED ELECTRICAL CONTINUITY
- ◆ SUITABLE FOR DEPOT OR VEHICLE USE
- ◆ ADJUSTABLE BRAKE, NO OVER RUN
- ◆ OPTIONAL CABLE GUIDE

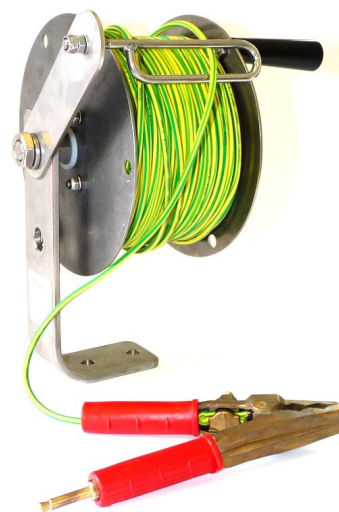

Introduction.

When transferring flammable liquids or powders at high flow rates it is essential that adjacent system components are electrically connected, or bonded, in order to reduce the risk from potentially explosive static electrical discharges. Traditionally this connection has been achieved using a bonding clip and cable stowed on an electrically conductive reel.

History.

In the past Bonding Reels were made from thick Aluminium or Brass castings, so in the event of failure or damage occurring it meant replacing a large expensive component. They relied on the hub bearing to provide the electrical circuit through the reel, but when the bearing got worn this resulted in a loss of continuity. The reeling resistance was low so during unreeling the reel continued to spin in an uncontrolled manner and put cable on the ground. The 'Aljac Bonding Cable Reel' has been specifically developed to overcome these shortcomings.

Description.

The 'Aljac Bonding Cable Reel' offers an extended operational life and it can be fully overhauled very simply. Our reel does not rely on contact between the hub and spindle for its electrical connection, instead it uses an internal spring loaded Graphite contact bush which is connected to the spindle and bears directly on a Brass sandwich plate which is

clamped to the side plate. This ensures a clean 100% contact. Because the hub is not required for continuity it is made from rigid PVC which provides a maintenance free bearing. Stainless steel is used for all other major components. A dedicated clip stowage point prevents clip loss and inadvertent unreeling during vehicular movement. The reel is fitted with an adjustable friction brake to eliminate over-run when unreeling.

The problem with our original design is that it was designed for highly flexible braided Copper cables. However, in certain regions it is common to see twisted core cable being used, which is much less flexible. When this cable is fitted to our original reel the small hub diameter causes the cable to take a permanent set into the coil shape, and consequently is not fully straight when laying on the ground, creating a trip hazard. So the new 'Large Hub Bonding Cable Reel' has been developed in order to accommodate these less flexible cable types. The reel can be fitted with an optional Cable Guide, and is fitted with a longer mounting bracket to give increased hand clearance under the handle assembly when rewinding. It will stow up to 30 metres of 4.5mm diameter cable.

The 'Aljac Bonding Cable Reel' has been risk assessed against the requirements of the EC directives and harmonised standards, including ATEX Directive 94/9/EC for use in Zone 1 hazardous areas, and it is CE marked.

General Arrangement Drawing.

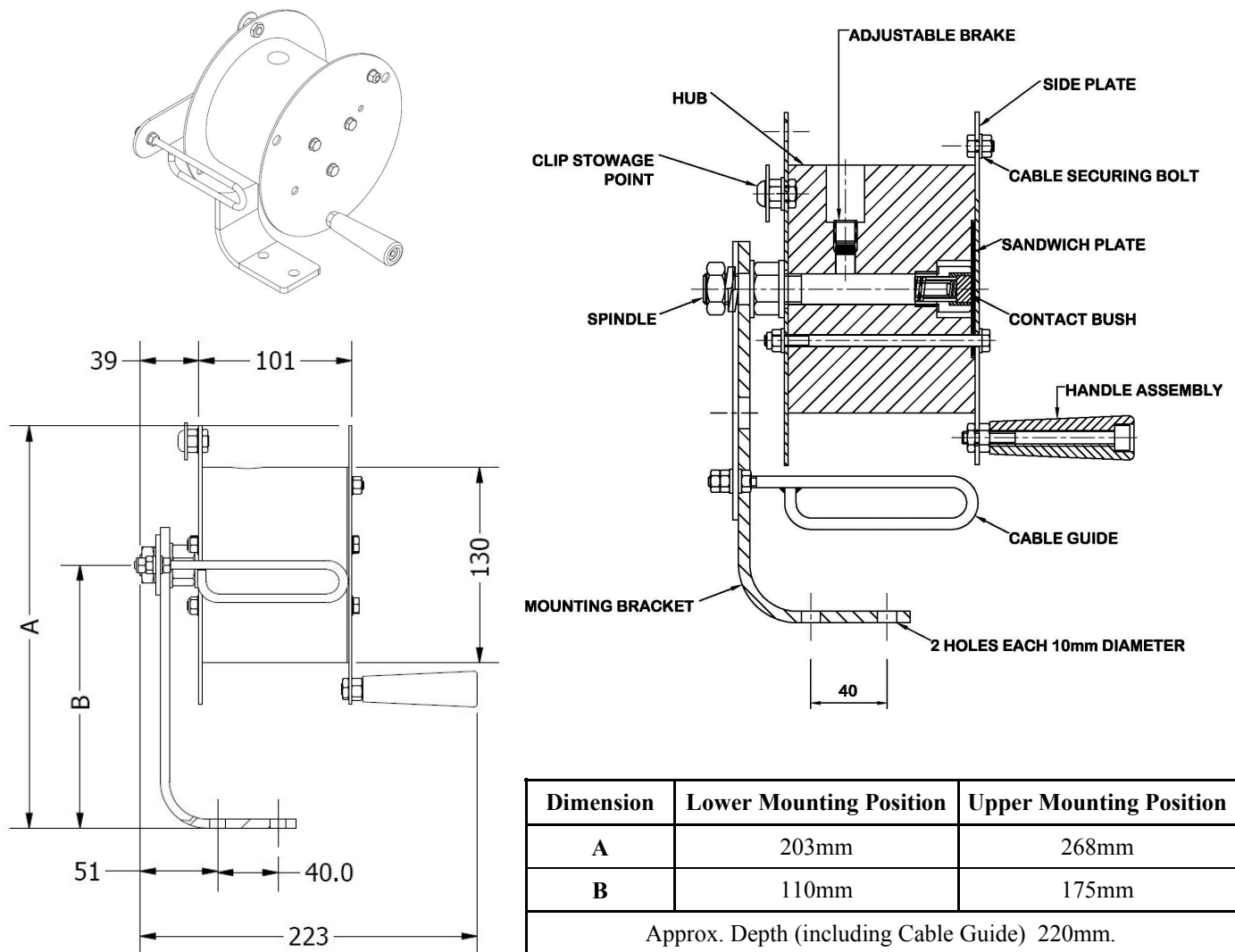

Dimension	Lower Mounting Position	Upper Mounting Position
A	203mm	268mm
B	110mm	175mm
Approx. Depth (including Cable Guide) 220mm.		

Applicable Standards.

Our Bonding Cable Reels have been assessed against and comply with the following standards:-
 94/9/EC. Directive on equipment and protective systems intended for use in potentially explosive atmospheres (ATEX).
 2006/42/EC. Directive on machinery.
 BS EN 13463-1:2009. Non-electrical equipment for use in potentially explosive atmospheres – Part 1: Basic method and requirements.
 BS EN 13463-5:2011. Non-electrical equipment intended for use in potentially explosive atmospheres. Protection by constructional safety 'c'.
 BS EN 1127-1:2011. Explosive atmospheres. Explosion prevention and protection. Basic concepts and methodology.

The reel is suitable for use in Zone 1 Category 2 (Gas and Dust) hazard areas, when installed, operated and maintained in accordance to the operating manual, and carries the following markings:

CE  II 2 G c IIC T6.

CE  II 2 D c.

Specification.

Capacity 0100211020:- 30 metres of 4.5mm outside diameter cable.

Material: Type 304 Stainless Steel with rigid PVC hub, Graphite Contact Bush.

Electrical Resistance: 0.5 Ohms max. (reel only).

Shipping weight: 2.3 Kg (reel only).

How To Order.

Part Number	Description
0100211020	Large Hub Bonding Cable Reel, no cable.
0100211013	Adjustable cable guide/bracket.

Please contact our Sales Department or see our Data Sheet DSS0240 for alternative cable and clip types.