

BONDING CABLE REEL

- ◆ COMPACT AND LIGHTWEIGHT
- ◆ ROBUST STAINLESS STEEL CONSTRUCTION
- ◆ IMPROVED ELECTRICAL CONTINUITY
- ◆ SUITABLE FOR DEPOT OR VEHICLE USE
- ◆ ADJUSTABLE BRAKE, NO OVER RUN
- ◆ OPTIONAL CABLE GUIDE

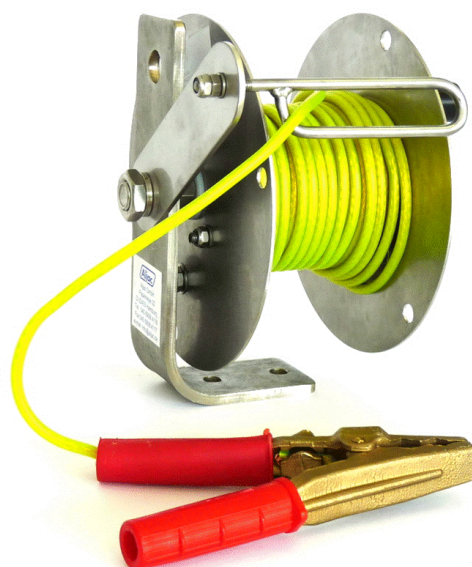

Introduction.

When transferring flammable liquids or powders at high flow rates it is essential that adjacent system components are electrically connected, or bonded, in order to reduce the risk from potentially explosive static electrical discharges.

Traditionally this connection has been achieved using a bonding clip and cable stowed on an electrically conductive reel.

History.

In the past Bonding Reels were made from thick Aluminium or Brass castings, so in the event of failure or damage occurring it meant replacing a large expensive component. They relied on the hub bearing to provide the electrical circuit through the reel, but when the bearing became worn this resulted in a loss of continuity. The reeling resistance was low so during unreeling the reel continued to spin in an uncontrolled manner and deposited cable on the ground.

The 'Aljac Bonding Cable Reel' has been specifically developed to overcome these shortcomings.

Description.

The 'Aljac Bonding Cable Reel' offers an extended operational life and it can be fully overhauled very simply. Our reel does not rely on

contact between the hub and spindle for its electrical connection, instead it uses an internal spring loaded Graphite contact bush which is connected to the spindle and bears directly on a Brass sandwich plate which is clamped to the side plate. This ensures a clean 100% contact. Because the hub is not required for continuity it is made from rigid PVC which provides a maintenance free bearing. Stainless steel is used for all other major components. A dedicated clip stowage point prevents clip loss and inadvertent unreeling during vehicular movement.

The 'Aljac Bonding Cable Reel' is available in two sizes, to accommodate up to 15 metres or up to 40 metres of cable. A heavy duty insulated Brass clip is fitted together with the required length of cable. The standard cable is transparent PVC insulated 16x14x0.15 Copper braid. The reel is fitted with an adjustable friction brake to eliminate over-run when unreeling. The reel can also be fitted with an optional adjustable cable guide which allows the cable to be pulled out at an acute angle without it fouling on the side plates.

The 'Aljac Bonding Cable Reel' has been risk assessed against the requirements of the EC directives and harmonised standards, including ATEX Directive 94/9/EC for use in Zone 1 hazardous areas, and it is CE marked.

General Arrangement Drawing.

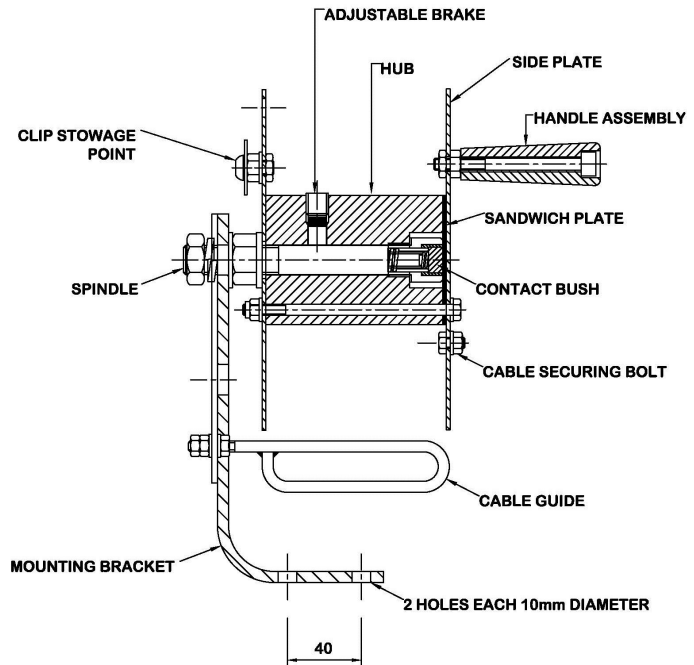
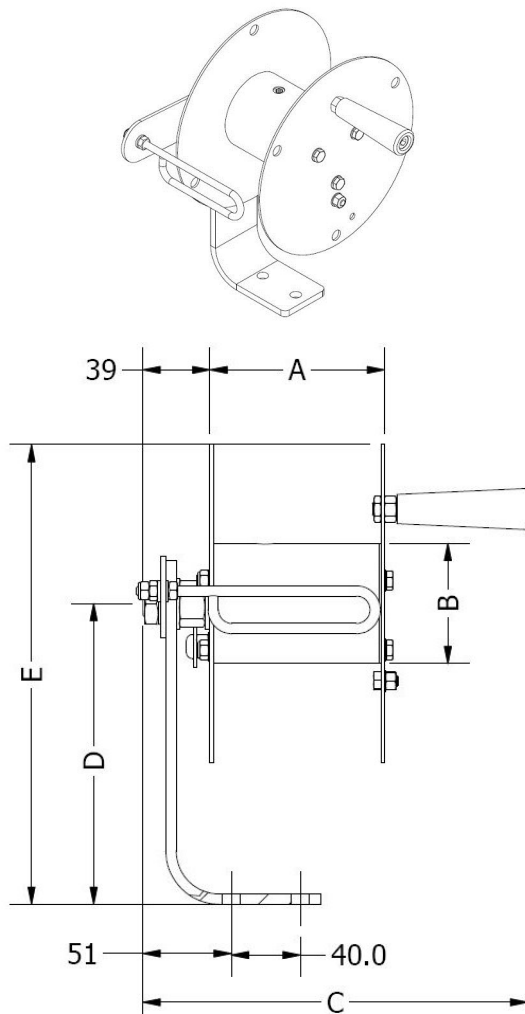

Dimension	Lower Mounting Position		Upper Mounting Position	
	0100211004	0100211010	0100211004	0100211010
A	73mm	101mm	73mm	101mm
B	70mm	70mm	70mm	70mm
C	193mm	223mm	193mm	223mm
D	110mm	110mm	175mm	175mm
E	203mm	203mm	268mm	268mm

Approx. Depth (including Cable Guide) 220mm for all versions.

Applicable Standards.

Our Bonding Cable Reels have been assessed against and comply with the following standards:-
 94/9/EC. Directive on equipment and protective systems intended for use in potentially explosive atmospheres (ATEX).
 2006/42/EC. Directive on machinery.
 BS EN 13463-1:2009. Non-electrical equipment for use in potentially explosive atmospheres – Part 1: Basic method and requirements.
 BS EN 13463-5:2011. Non-electrical equipment intended for use in potentially explosive atmospheres. Protection by constructional safety 'c'.
 BS EN 1127-1:2011. Explosive atmospheres. Explosion prevention and protection. Basic concepts and methodology.

The reel is suitable for use in Zone 1 Category 2 (Gas and Dust) hazard areas, when installed, operated and maintained in accordance to the operating manual, and carries the following markings:

CE  II 2 G c IIC T6.

CE  II 2 D c.

Specification.

Capacity (5.5mm outside diameter cable):
 0100211010, 40 metres. 0100211004, 15 metres.
Material: Type 304 Stainless Steel with rigid PVC hub, Graphite Contact Bush.
Electrical Resistance: 0.5 Ohms max. (reel only).
Shipping weight (reel only): 0100211010 2.2 Kg.
 0100211004 1.9Kg.

How To Order.

Part Number	Description
0100211010	Bonding Cable Reel, 40m, no cable.
0100211013	Adjustable cable guide/bracket (40m reel).
0100211004	Bonding Cable Reel, 15m, no cable.
0100211014.	Adjustable cable guide/bracket (15m reel).
0100212001	Bonding Cable, Copper braid, clear PVC cover, specify length.
0100212005	Bonding Cable, Copper braid, high visibility cover, specify length.
0100213001	Bonding Clip, 70mm long.

Please contact our Sales Department or see our Data Sheet DSS0240 for alternative cable and clip types.