

## HIGH CAPACITY SPRING REWIND BONDING REEL

- ◆ **HIGH CAPACITY, ACCEPTS UP TO 40 METRES OF CABLE**
- ◆ **CONTROLLED REWIND SPEED**
- ◆ **HEAVY DUTY DESIGN, LONG SERVICE LIFE**
- ◆ **MAINTENANCE FREE CONSTRUCTION**

### Introduction.

For many years spring rewind bonding reels have suffered from poor reliability and have lacked resistance to operational abuse, particularly under the most severe operating conditions. In addition, they have not been able to accept large volumes of cable.

There has always been the need for this product, particularly by the military, but no reel has been able to fully overcome the traditional problems at a sensible price. Aljac Fuelling Components is now able to offer the High Capacity Spring Rewind Bonding Reel to fulfill this need.

### Description.

Our High Capacity Spring Rewind Bonding Reel has been designed to accommodate up to 40 metres of 5.5 mm diameter cable, as specified by the major fuel supply companies and the British Ministry Of Defence. It is of a latched design, the cable is simply pulled out to the required position and the latch holds the reel. To release the latch and initiate rewinding the cable is given an extra pull. The latch mechanism requires no lubrication and can easily be removed if the reel is to be used in a non-latching configuration.

The heart of this reel is the Stainless Steel Tensator torsion spring. This spring has a design life of 20,000 cycles and is contained in a fully



sealed housing, so no water or dirt can affect its correct operation. The rewind speed is controlled using a Silicone fluid damping system which is inherently reliable, and is unaffected by large temperature variations. Its performance will also not deteriorate due to mechanical wear and tear. In older designs the combination of complex rewind speed control devices with the low spring quality has been the major reason for premature failure when operator abuse takes place.

The reel is completed with an adjustable cable guide to ensure that the cable is rewound accurately onto the drum.

Since its introduction this reel has been successfully tested and approved by the British Ministry Of Defence, and has been proven in widespread service all over the world.

## Dimensional Drawing.

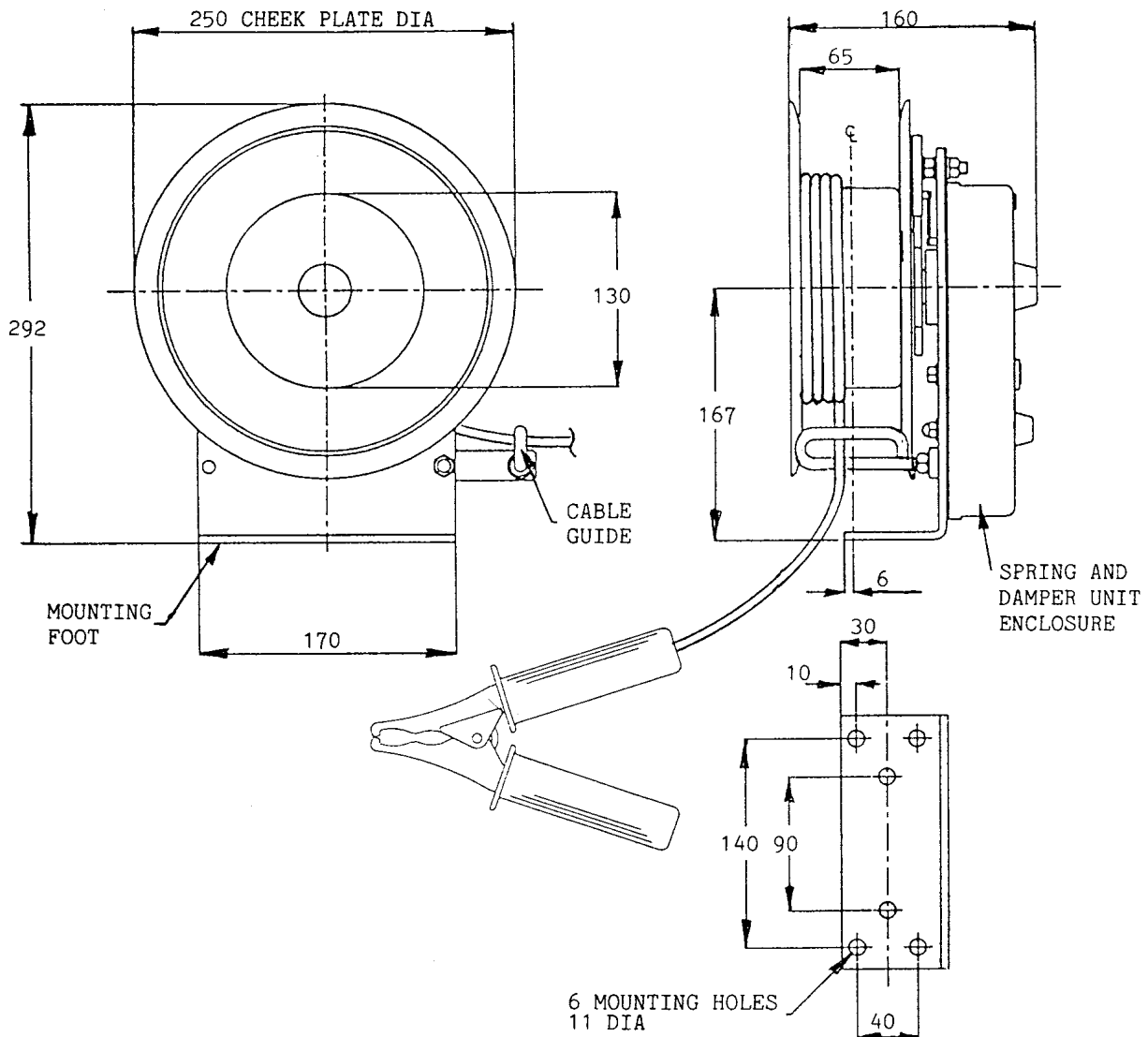

### Detailed Specification.

Reel Type:- Spring rewind, with latch, automatic speed control and adjustable cable guide.

Material Of Construction:- Zinc plated Steel drum and mounting bracket, cast Aluminium housing, Stainless Steel spring.

Maximum Resistance:- 0.5 Ohms (Bonding Clip to base plate when fitted with up to 40 metres of 16x14x0.15 Copper braid cable).

Minimum Operating Temperature:- Minus 40 deg. C.

### Shipping Specification.

Shipping Weight:- 10 Kg (no cable fitted)

Overall Dimensions:- 250 mm by 160 mm by 292 mm.

### How To Order.

Contact Aljac Fuelling Components and ask for part number 0100215040 for the reel without cable. A stop ball (part number 0100213025) and Cable Clamp part number (0100213026) will also be required.

### Accessories.

Aljac Fuelling Components can supply clear PVC covered and High Visibility Copper braid bonding cable, a wide variety of Bonding Clips, Bonding Plugs, and Break Away Joints for use with this reel.

Please contact our Sales Department to discuss your exact requirements.