

## **HYDRANT PIT AND DISPENSER INLET HOSE VISIBILITY**

### **Introduction.**

A number of incidents in recent years have demonstrated the need to increase the visibility of the hydrant pit and dispenser inlet hose, particularly during night time refuelling. Collisions between aircraft servicing vehicles and hydrant pits or inlet hoses are becoming more common, both in darkness and in daylight, in good or poor weather conditions. In the event of the dispenser inlet system sustaining major damage from such a collision, high pressure Jet fuel could be released at a high flow rate, and one day this could have catastrophic effects, including fire and loss of life.

The current level of risk coupled with an increasing number of near misses prompted the Joint Inspection Group (JIG), to issue a Safety Bulletin entitled 'Hydrant Pit Identification', which identified a number of key actions to improve pit and hose visibility. In order to meet this need Aljac Fuelling Components has developed the following pieces of equipment.

### **Intake Hose Covers and Pit Flags.**

Our intake hose covers and pit flags are manufactured from the highest quality reinforced vinyl, they are double thickness and stitched with Nylon thread. The base material is bright orange and fade resistant for good daytime visibility. The ultra high reflective strip material gives excellent night time visibility and is plastic encapsulated to ensure long life.

We have used high quality materials throughout these products because the working conditions are so arduous. As a result our intake hose covers and pit flags last longer and perform better than traditional pennant type flags and chevron type intake hose covers. This is particularly evident when they are exposed to abrasion and degradation from road dirt, vehicle pressure wash systems and severe climatic conditions.

**QUESTION. Are your dispensers as visible as this one at dusk when it is raining ?**



### **Intake Hose Covers.**

Our intake hose covers have the following advantages:-

***Secure.*** Fastened using Velcro and press studs.

***Easy Removal.*** Essential for hose inspection, not affected by grit and corrosion.

***Dual Size.*** Twin rows of Velcro and press studs allow the cover to be fitted to a hose or boom, under or over the sense lines. The end of the cover can be cut off if the smaller position is required.



## High Visibility Pit Flag.



Our pit flags are suitable for use in place of the traditional pennants on conventional flag poles, or in conjunction with our new Four Winged Flag.

They have the following advantages over traditional pennants :-

**Modern Design.** Fully in accordance with the principles of the new JIG Safety Bulletin.

**Secure.** Metal eyelets to fasten to the flag pole and prevent tearing, open ended loop to prevent wear on the end of the flag.

**Multi Purpose.** Suitable for use with conventional flag poles and new four winged designs up to 35mm diameter.

**Highly Visible.** Bright orange background and highly reflective crosses, out performs the materials suggested in the JIG Safety Bulletin.

**Longer Lasting.** Top quality materials and workmanship ensure extended service life with minimal deterioration.

## Four Winged Flag.

One of the key needs identified in the JIG Safety Bulletin was for a Four Winged Flag. It was considered sufficiently important to be classified as a minimum requirement for hydrant pit identification. It has to be highly visible from any direction in the day or night, and set at a height which allows it to be seen from the cab of airport ground support vehicles. We fully support the concept of the Four Winged Flag, but there have been a number of practical problems such as the weight, the short service life (in some cases as little as 2 weeks), and difficult stowage on the vehicle. By consulting the refuelling companies at the major UK airports we have overcome these problems to make our Four Winged Flag operationally acceptable. It uses a unique swivel head design as shown below.

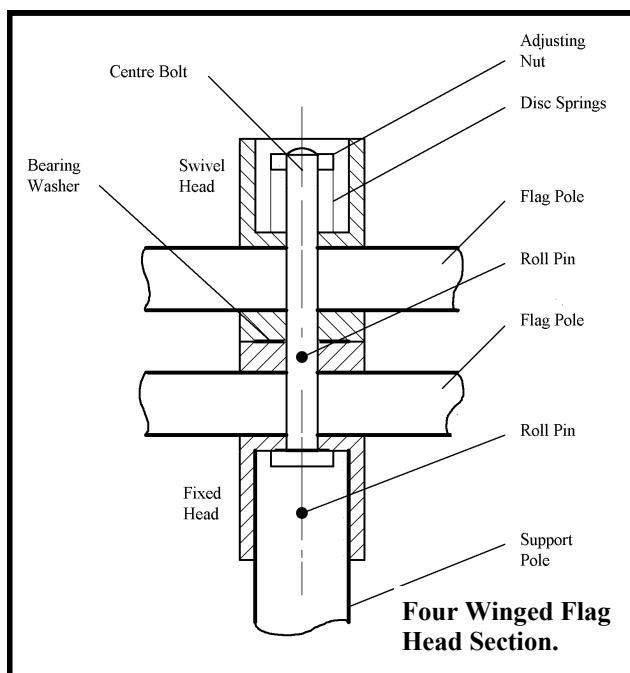
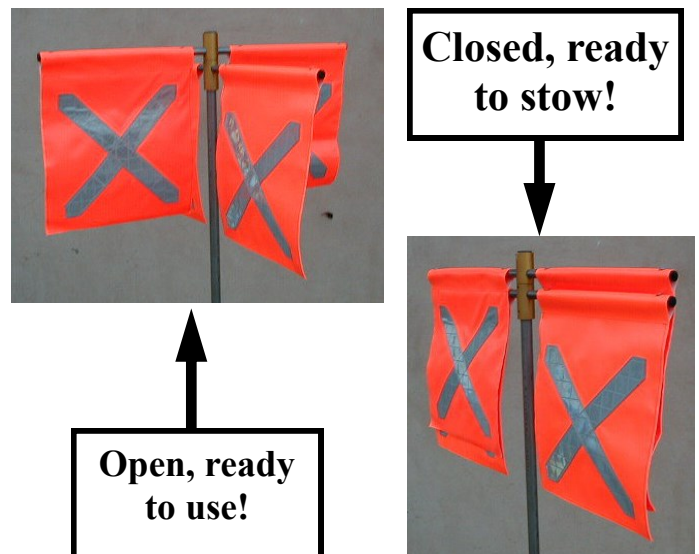

Our Four Winged Flag has the following advantages :-

**Simple design.** No catches or complicated mechanisms to fail.

**Adjustable.** Our swivel head can be adjusted to set the operating torque to the level which suits you, and to compensate for wear.

**Lightweight.** We have simplified the head design and used thin wall Stainless Steel tube for the poles to reduce the weight.

**Easy Stowage.** Our design folds flat to a Tee shape for stowage in a tube type holder or U bracket.

**Maximum Flag Life.** The flags hang vertically without folding when the unit is stowed.

**Durable.** There are no protruding parts to suffer impact damage.

**No Sharp Edges.** Tube ends are fitted with moulded plastic plugs to the reduce risk of operator injury.

### Detailed Specifications.

#### Intake Hose Covers.

Base Material. Double thickness fabric reinforced vinyl, bright orange, stitched with Nylon thread.

Reflective Material. Plastic encapsulated, 50mm wide, 3 strips.

Overall Sizes. 330mm wide, 550mm long (fully opened out).

Securing Method. 3 press studs with 50mm wide Velcro strips.

Net Weight. 300 Grams.

#### Four Winged Flag.

Materials.

Head Aluminium Alloy, anodized Gold.

Flag Poles type 304 Stainless Steel 3/4" diameter by 16 SWG welded tube.

Support Pole type 304 Stainless Steel 1" diameter by 16 SWG welded tube.

Bearing Washer Nylon, moulded PVC tube end plugs, Stainless Steel Centre Bolt.

Overall Sizes. As drawing.

Net Weight. Approximately 4 Kg (flags fitted).

Flags Secured by 4mm diameter Aluminium pop rivets, 2 off per flag.

Torque Adjustment. M10 Nylok nut on Stainless Steel spring washers.

Shipped with Support Pole/Roll Pin loose to reduce shipping volume.

#### Pit Flags.

Base Material. Double thickness fabric reinforced vinyl, bright orange, stitched with Nylon thread.

Reflective Material. Plastic encapsulated, 50mm wide, one cross on each side.

Overall Sizes. 370mm wide, 430mm long (when not fitted to flagpole).

Securing Method. 2 off 5mm diameter metal eyelets.

Flagpole Diameter. 35mm maximum.

Net Weight. 250 Grams.

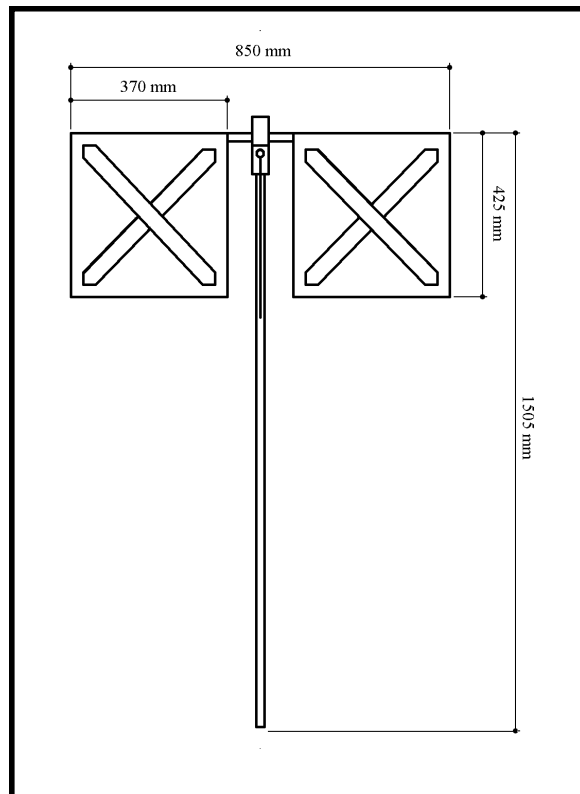

### How To Order.

Contact Aljac Fuelling Components and ask for the appropriate part numbers.

Description.	Part Number
Intake Hose Cover	5100000250
High Visibility Pit Flag	5100000300
Four Winged Flag Head , no Flags, no Support Pole (order separately)	5200000200
Four Winged Flag Support Pole	5200000300
Hose Clamp Flag Holder	5200000100

### Accessories.

We are constantly developing accessories to accompany this range of products. Please contact our Sales Department for the full range or if you need any advice on the use or application of these products.

We can supply Hose Clamp Flag Holders, modification kits to allow a Mounting Bracket to be attached to Meggitt Avery Hardoll and Eaton Carter intake couplers, and we can advise on stowage brackets to allow the Four Winged Flag to be carried on your dispensers.